

# FE-165 Light/Elite Robotic Elevation Unit



Part No. V4127-0002  
V4127-0003

**Copyright © 2015**

All rights reserved.

Original Instructions: English

All rights reserved throughout the world. No part of this document may be stored in a retrieval system, transmitted, copied or reproduced in any way, including, but not limited to, photocopy, photograph, magnetic or other record without the prior agreement and permission in writing of the Videndum Group plc.

**Disclaimer**

The information contained in this manual is believed to be correct at the time of printing. Videndum Ltd reserves the right to make changes to the information or specifications without obligation to notify any person of such revision or changes. Changes will be incorporated in new versions of the publication.

We are making every effort to ensure that our manuals are updated on a regular basis to reflect changes to product specifications and features. Should this manual not contain information on the core functionality of your product, please let us know. You may be able to access the latest revision of this manual from our website.

Videndum Ltd reserves the right to make changes to product design and functionality without notification.

**Trademarks**

All product trademarks and registered trademarks are the property of The Videndum Group Plc.

All other trademarks and registered trademarks are the property of their respective companies.

**Published by:**

Videndum Ltd

Supports Technical Publications Department

Western Way, Bury St Edmunds

Suffolk IP33 3TB

United Kingdom

Email: [technical.publications@vitecgroup.com](mailto:technical.publications@vitecgroup.com)

<b>Safety</b> .....	<b>2</b>	Power Connections .....	21
<b>About this User Guide</b> .....	<b>5</b>	Installation .....	21
<b>Components and Connections</b> .....	<b>6</b>	Cable Management .....	22
FE-165 Rear View .....	6	Powering Up .....	23
FE-165 Front View .....	7	<b>Operation</b> .....	<b>24</b>
FE-165 Leg Assembly .....	7	Operating the FE-165 - Safety Precautions .....	24
FE-165 Connection Panel .....	8	Moving the FE-165 or Adjusting the Payload .....	24
Standard Box Contents - Light and Elite .....	9	Leaving the FE-165 Unattended .....	25
Additional Box Contents - Elite Only .....	10	Using the Emergency Stop Button .....	26
Optional Accessories - Light and Elite .....	10	Using the Column Release Knob .....	27
Tools Required .....	11	Manual Operation Mode (Elite Only) .....	28
<b>Installation</b> .....	<b>12</b>	Indicator LEDs .....	29
Unpacking the FE-165 .....	12	<b>Maintenance</b> .....	<b>30</b>
Assembling the FE-165 .....	12	Routine Maintenance .....	30
Fitting the Cable Management Net .....	12	Cleaning .....	30
Adjusting the Cable Guards .....	13	Changing the Fuse .....	30
Operating the Wheel Brakes .....	14	Fitting the Leg Assemblies .....	31
Installing the Payload .....	14	<b>Troubleshooting</b> .....	<b>33</b>
Payload Assessment .....	14	<b>Technical Specification</b> .....	<b>34</b>
Fitting the Robotic Head .....	15	<b>General Notices</b> .....	<b>35</b>
Fitting the Camera and Accessories .....	17		
Fitting the Accessory Mounting Bracket (optional) .....	18		
Fitting the Elevation Controller (Elite Only) .....	19		
Connecting the FE-165 .....	20		
System Connections .....	20		

**Important information on the safe installation and operation of this product. Read this information before operating the product. For your personal safety, read these instructions. Do not operate the product if you do not understand how to use it safely. Save these instructions for future reference.**

## Warning Symbols Used in these Instructions

Safety cautions are included in these instructions. These safety instructions must be followed to avoid possible personal injury and avoid possible damage to the product.



### WARNING!

Where there is a risk of personal injury or injury to others, comments appear supported by the warning triangle symbol. Where there is a risk of damage to the product, associated equipment, process or surroundings, comments appear supported by the word '**Caution**'.



### ELECTRIC SHOCK

Where there is a risk of electric shock, comments appear supported by the hazardous voltage warning triangle.

## Intended Use

The FE-165 Light and Elite robotic elevation units are designed to support a robotic head and camera together with ancillary equipment weighing up to 75 kg (165 lb).

Camera operators can remotely control the height axis using Vinten control systems.

The FE-165 Light and Elite are designed for use in a TV studio environment or on outside broadcasts (OB) when protected from weather by a suitable waterproof cover.

## Electrical Connection



**WARNING! Risk of electric shock.** Always disconnect and isolate the product from the power supply before attempting any servicing or removing the covers.



**WARNING! Risk of electric shock.** Always check cables for signs of damage. Damaged cables can cause personal injury and/or damage the equipment.



**WARNING!** It is the responsibility of the local organisation to ensure that the product is periodically checked for electrical safety in accordance with local regulations.



**CAUTION!** This product must be connected to a power supply of the same voltage (V) and current (A) as indicated on the product. Refer to the technical specifications for the product.



**CAUTION!** Limit the primary AC supply cable (floor cable) current to a maximum of 16A (via the AC wall socket or fused connection).



**CAUTION!** All connections to other devices must be made using shielded cables.



**CAUTION!** Using alternative power sources will invalidate the system EMC liability.



**CAUTION!** Do not exceed the current output limit of the product when powering auxiliary devices.



**CAUTION!** Always use a fuse of the correct type and rating for the product. Refer to the Technical Specifications for the product.



**CAUTION!** The product must be connected to the AC supply using a 30 mA RCD unit.

## Basic Electrical Insulation (Class 1 Equipment)



**WARNING!** This product is Class 1 equipment. For safe operation this equipment must be connected to a power supply that has a protective earth connection (US: ground).

## Health and Safety



**WARNING! Risk of personal injury or injury to others.** All personnel must be fully trained and adhere to correct manual handling techniques and Health & Safety regulations. It is the responsibility of the local organisation to enforce safe working practices at all times.



**WARNING!** 50.4 kg/111.1 lb LIFTING ASSISTANCE REQUIRED. Do not lift this product without the assistance of another person or a lifting hoist capable of safely lifting the product.

## Mounting and Installation



**WARNING!** Before fitting, adjusting, or removing the payload, the elevation column must be lowered to a safe working height and all four castor wheel brakes must be applied.



**WARNING!** An abnormal or unbalanced payload can cause the product to become unstable. Strictly adhere to the payload guidelines and mounting instructions presented in this user guide.



**WARNING!** When mounting the payload, sufficient clearance must be provided below the mounting platform to prevent the risk of collisions or trapping injuries when the column is lowered.



**WARNING!** Always ensure that all power and auxiliary communications cables are routed so that they do not present any danger to personnel. Take care when routing cables in areas where robotic equipment is in use.

## Operation



**WARNING!** An emergency stop button is located on the product for safety. All personnel working with, or within the operating area of the product must be made aware of the location and function of the button.



**WARNING!** The product has been designed for mounting a payload consisting of camera support equipment only. Under no circumstances should the product be used for the transportation or support of personnel.



**WARNING!** Risk of product instability when moving the product with the elevation column fully extended. Reduce the height of the elevation column to a safe lower level before attempting to move the product.



**WARNING!** The product must only be operated on a smooth and flat surface.



**WARNING!** The product must always be secured (all four wheel brakes applied) when left unattended. Do not leave the product unattended on a sloping surface.



**CAUTION!** Do not exceed the payload limit for the product of 75 kg (165 lb).



**CAUTION!** The product must only be operated with a minimum payload of 30 kg (66.1 lb) to pre-load the column correctly.

# Safety

## Water, Moisture and Dust



**WARNING!** Protect the product from water, moisture and dust. The presence of electricity near water can be dangerous.

## Ventilation



**CAUTION!** Slots and openings are intended for ventilation purposes to ensure reliable operation of the product and protect it from overheating. Do not block or cover any slots and openings.

## Operating Environment



**CAUTION!** The product should not be used outside the operating temperature limits. Refer to the product technical specifications for the operating limits for the product.

## Cleaning



**WARNING! Risk of electric shock.** Always disconnect and isolate the product from the power supply before cleaning.



**CAUTION!** Do not use abrasives or wire brushes to clean the product. Clean with a soft dry cloth.

## Maintenance



**WARNING!** This product is fitted with a pressurised gas vessel. The removal of any covers, and the undertaking of any servicing or repair work must only be carried out by approved and qualified service engineers.



**WARNING!** The fitting of non-approved parts or accessories, or the carrying out of non-approved alterations or servicing can be dangerous and could affect the safety of the product. It may also invalidate the terms and conditions of the product warranty.

## Safety when Working with Robotic Equipment

In normal operation remote-controlled equipment can move suddenly and without warning. Since audible warnings are not suitable for use within the studio environment, it is recommended that only trained personnel be allowed to work in the active areas where remote-controlled robotic equipment is located.

The safe operating zone is a minimum of 1 m (3 ft).

## Safety Notes for Operators

Operators must familiarise themselves with the working footprint of the robotic equipment, including all installed payload items (lens, zoom and focus controls, viewfinder, prompter, etc.) to prevent inadvertent collisions or injury to personnel.

If personnel are too close to robotic equipment that is about to move, the operator should prevent the motion from starting or stop the motion if it has started.

We strongly recommend that the operator verifies visually that the active area is clear of hazards and personnel, both before and during remote operation.

## Introduction

The Vinten FE-165 Light and Elite robotic elevation units have been designed to integrate with compatible robotic pan and tilt heads and controllers to form part of a robotic camera support system installation.

The FE-165 Light and Elite have been designed to accommodate specific robotic pan and tilt heads and form part of a robotic system installation. The Light and Elite variants also have different operational features. See the compatibility section below.

This user guide covers the installation, configuration and operation of both variants of the FE-165.

## Compatibility

The following table shows the key differences between the FE-165 variants.

		Robotic Head	Manual Operation
V4127-0002	FE-165 Elite	FH-145	✓
V4127-0003	FE-165 Light	FHR-145	✗



For illustrative purposes, the FE-165 Light variant is used throughout the guide unless otherwise stated.

# Components and Connections

## FE-165 Rear View

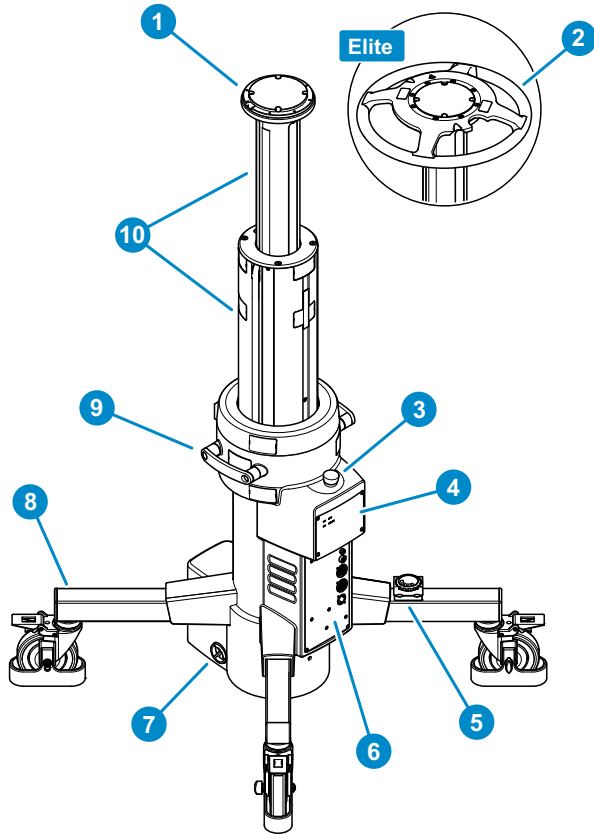

1	Head mounting plate
2	Steering wheel (Elite only)
3	Emergency stop button
4	Indicator LEDs and data connection panel
5	Leg cable clamp
6	Power connection panel
7	Column release knob
8	Leg assembly (x4)
9	Grab handle (left side)
10	Elevation column moving sections



## FE-165 Front View

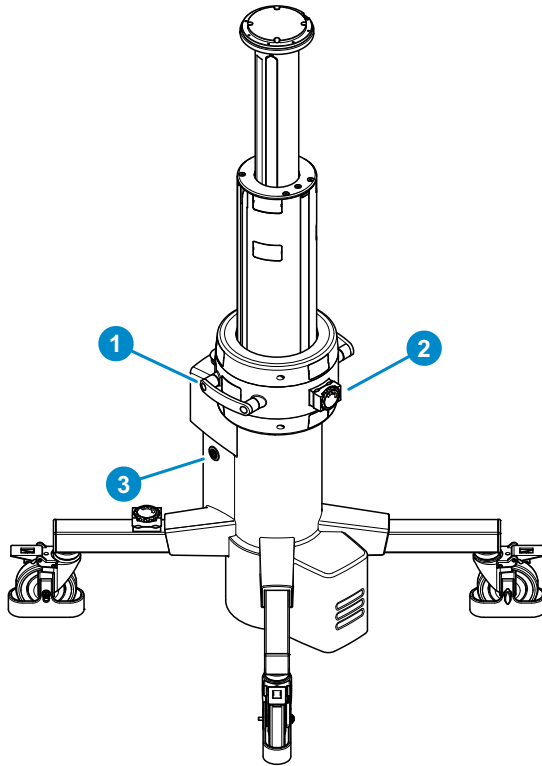

## FE-165 Leg Assembly

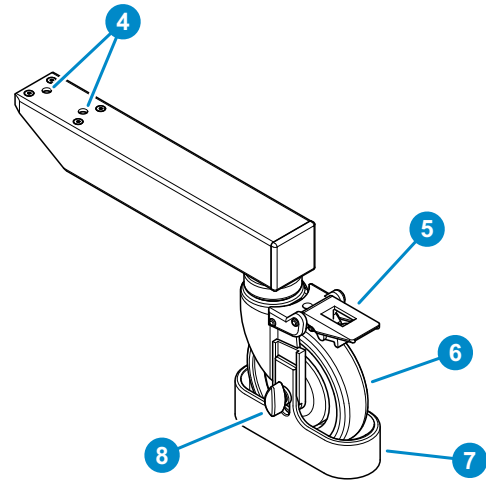

- |   |                                   |
|---|-----------------------------------|
| 1 | Grab handle (right side)          |
| 2 | Main body cable clamp             |
| 3 | Power switch                      |
| 4 | Fixing holes                      |
| 5 | Wheel brake                       |
| 6 | Swivel wheel                      |
| 7 | Cable guard                       |
| 8 | Cable guard adjustment clamp knob |

# Components and Connections

## FE-165 Connection Panel

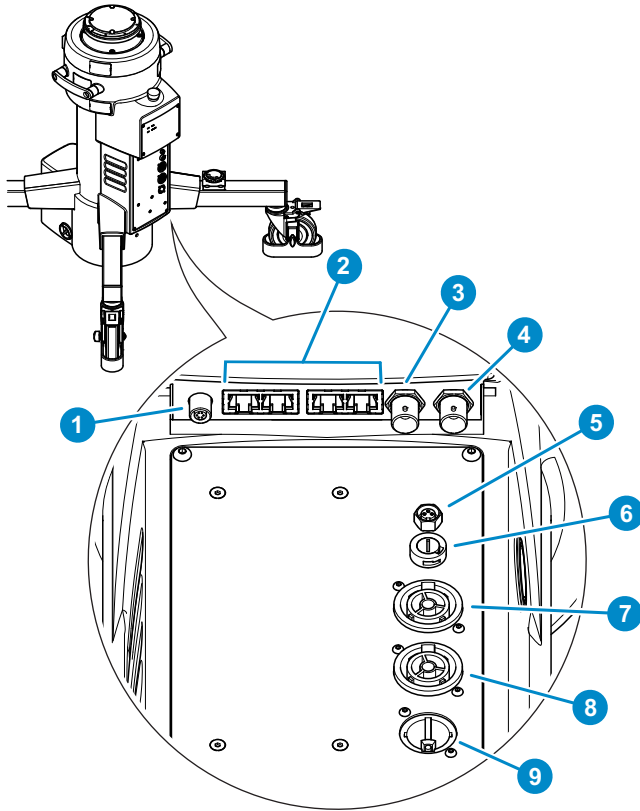

1	Elevation controls connector (Elite only)
2	Ethernet ports (x4)
3	Genlock IN connector
4	Genlock OUT connector
5	48 VDC OUT connector (currently not used)
6	Fuse holder
7	AC power OUT connector, switched
8	AC power OUT connector, switched
9	AC power IN connector

## Standard Box Contents - Light and Elite

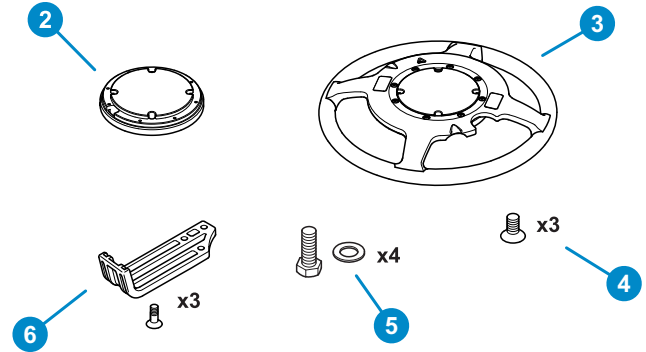
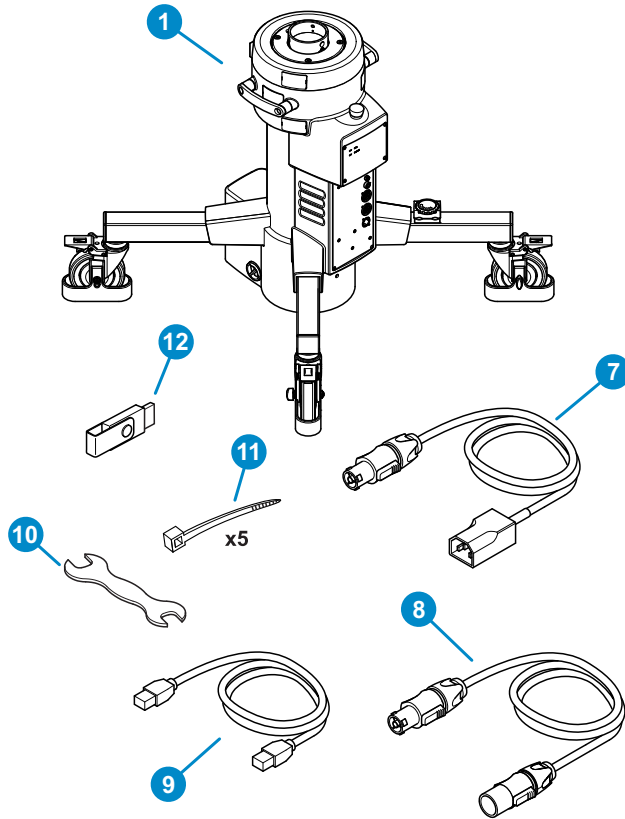

1	FE-165 Light or Elite main body assembly
2	Head mounting plate (Lite only)
3	Head mounting plate with steering wheel (Elite only)
4	Head mounting plate fixing screws, x3
5	3/8 in. head fixing bolts and washers x4
6	Cable management bracket and fixing screws (Light only)
7	AC power cable, 3 metres
8	AC robotic head power cable, 3 metres
9	Network cable, 3 metres
10	Vinten spanner (for head bolts)
11	Cable ties, x5
12	USB stick containing software and documentation

# Components and Connections

## Additional Box Contents - Elite Only

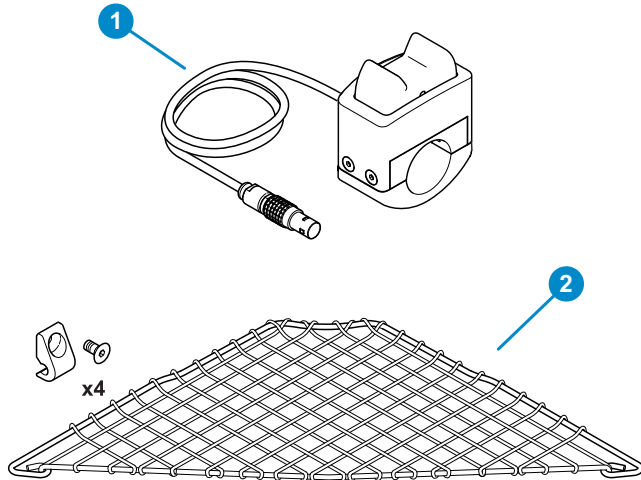

1	Elevation hand controller
2	Cable management net and fixings

## Optional Accessories - Light and Elite

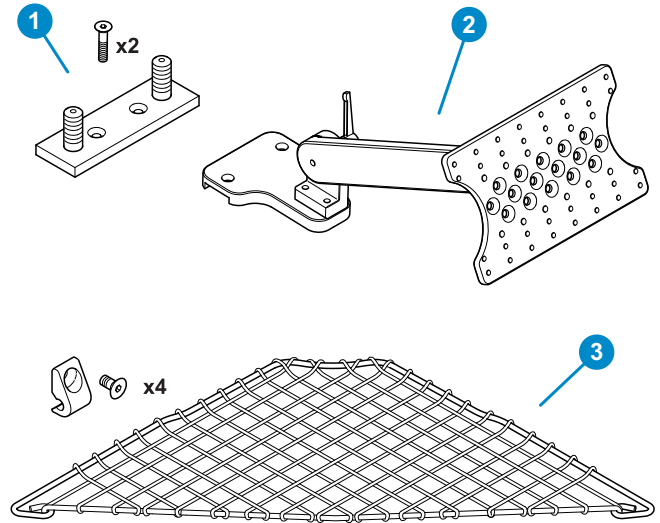

1	Accessory mounting bracket
2	Autoscript Universal On-Air Mounting Bracket (part no. MT-OA-UNI)
3	Additional cable management nets

## Tools Required

Metric Allen key set.

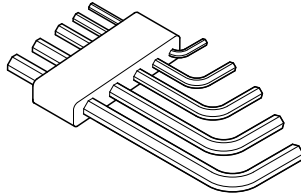

Pozidriv® PZ-1 screwdriver.

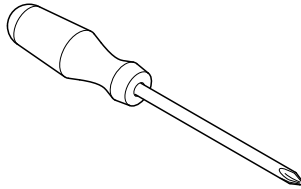

Vinten Spanner (5/16 in.).

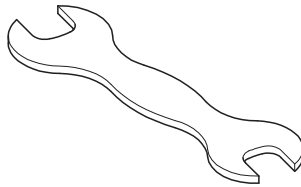

Torque screwdriver with metric hex bits.

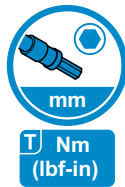
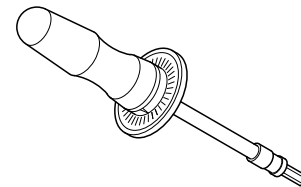

# Installation

## Unpacking the FE-165



**WARNING! Risk of personal injury or injury to others.**

1. DO NOT lift the elevation unit unaided. This product weighs up to 50.4 kg (111.1 lb).
2. DO NOT lift the product by the camera mounting plate.



**WARNING!** If the FE-165 has been received or subsequently transported with the legs removed, these must be fitted before any other installation work can be carried out. See the section **Maintenance** on page 30.

1. With the assistance of another person, use the two grab handles on the sides of the FE-165 to carefully lift it from the transportation box.

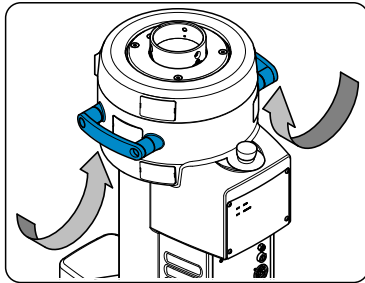

2. Remove all the other product components from the transportation box.
3. Ensure that all transportation packaging material and retaining fixings are removed from the product components.

## Assembling the FE-165

### Fitting the Cable Management Net

The cable management net can be installed on the FE-165 to provide storage of additional cables or management of excessive cable lengths and bundles.

1. Fit the cable management net between the two rear legs of the FE-165, securing in position with the four screws provided.

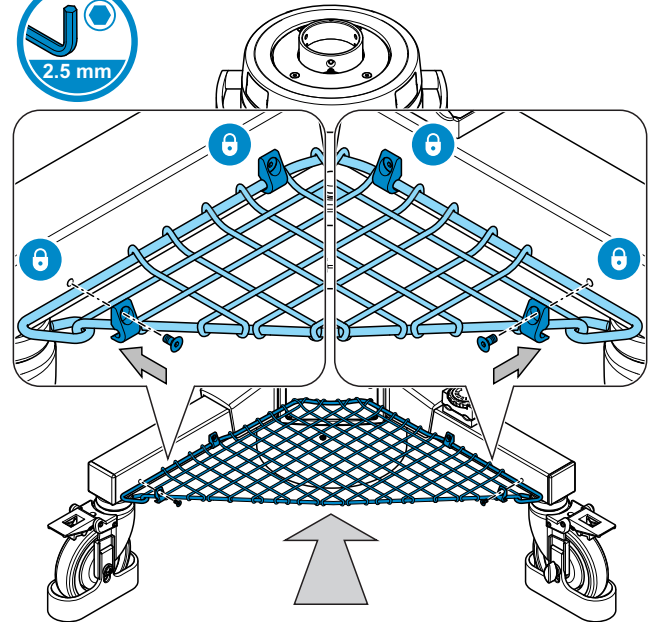

2. A further two cable management nets can be fitted to the sides of the FE-165, if this is a requirement of the installation.

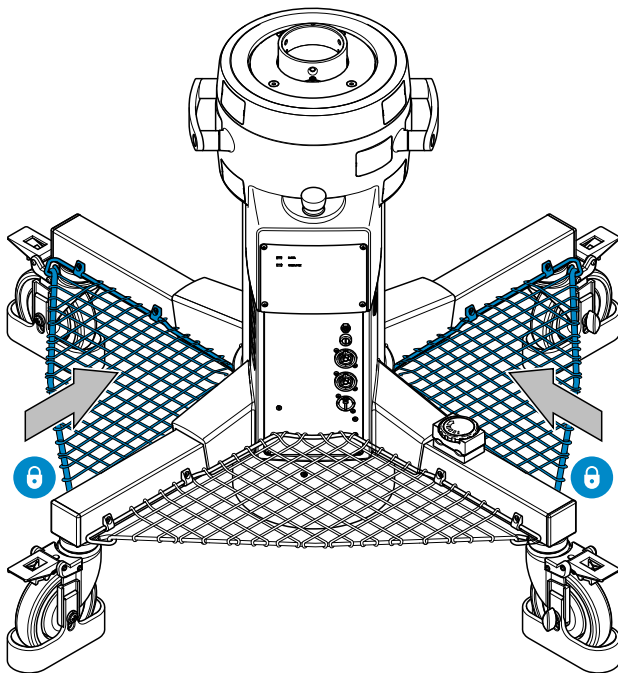

## Adjusting the Cable Guards

Each of the four castor wheels is fitted with a cable guard. These are height adjustable and should be set as required for the installation.



**WARNING!** To avoid the risk of wheel collision with smaller cables, all four cable guards must be set to a maximum height clearance of 3 mm (0.12 in.) above the floor level.

1. Loosen the locking knob on the side of the cable guard.

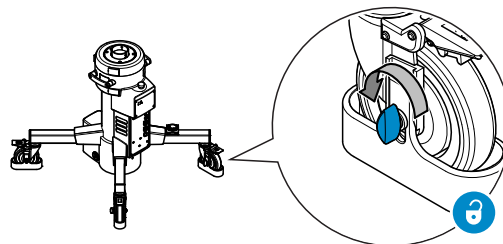

2. Slide the cable guard to the required height level and secure in position by re-tightening the locking knob.

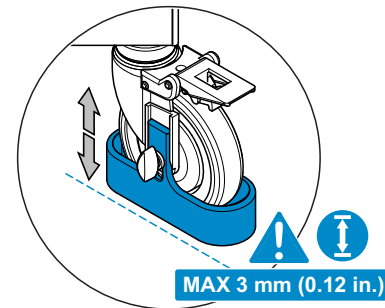

3. Adjust the other three cable guards to the same level requirement.

# Installation

## Operating the Wheel Brakes

The wheels on the FE-165 are fitted with foot operated wheel brakes. All four wheel brakes must be applied to ensure the unit is stable and held firmly in position.

### Applying the Wheel Brakes

Press down firmly on the top of the lever to latch the brake into the locked position.

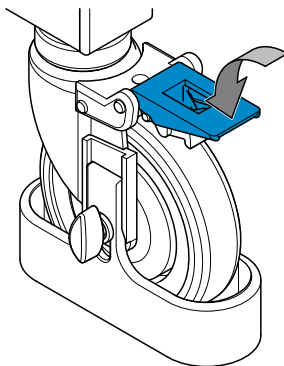

### Releasing the Wheel Brakes

To release, press down firmly on the centre 'pop-up' lever which is raised when the brake is on.

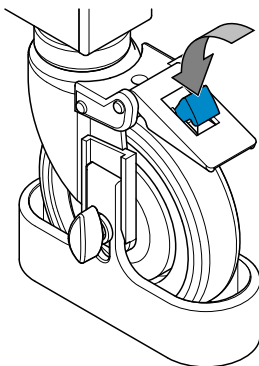

## Installing the Payload



**CAUTION! Risk of product damage.** The product must only be operated with a minimum payload of **30 kg (66.1 lb)**. Do not exceed the payload limit for the product of **75 kg (165 lb)**. Ensure that the payload has been correctly assessed.

### Payload Assessment

It is critical for the correct and safe operation of the FE-165 that the payload to be installed is assessed to meet the following criteria:

1. Accurately calculate the total weight of the payload to be fitted to the elevation unit. The total weight must be at least **30 kg (66.1 lb)** but not exceed **75 kg (165 lb)**.

FH-145

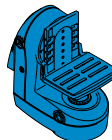

28.4 kg (62.5 lb)

FHR-145

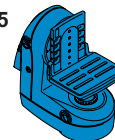

24.2 kg (53.5 lb)

OR

+

Camera body and lens

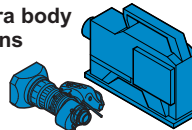

Ancillary equipment

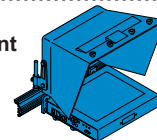

$\leq 75$  kg (165 lb)



2. Ensure that the camera, lens and any other equipment can be centrally balanced on the robotic head (i.e. the mounting plate of the elevation column).

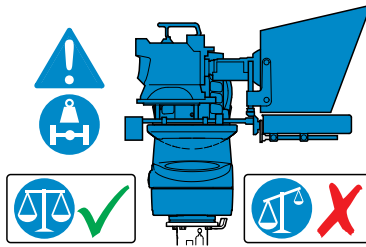

3. Ensure that provision is given for sufficient clearance below the mounting platform to prevent the risk of collisions or trapping injuries when the column is lowered.

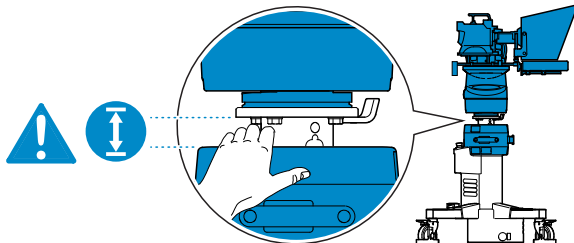

4. Measure to check that the overall length of the payload will not exceed 700 mm (27.5 in.) from the centre of the mounting plate in any direction.

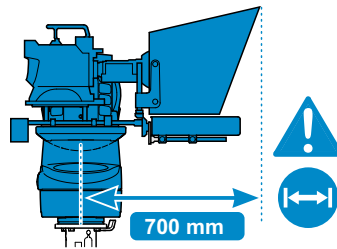

## Fitting the Robotic Head



**WARNING!** Before fitting, adjusting, or removing the payload, the elevation column must be lowered to a safe working height and all four wheel brakes must be applied. Do not attempt to install the robotic head with the camera or any payload attached.

The robotic head (FH-145 for Elite / FHR-145 for Light) is fitted to the FE-165 using a head mounting plate.

1. If required in this installation, attach the cable management bracket (Light only) to the underside of the head mounting plate. Secure the bracket in position with the three screws provided.

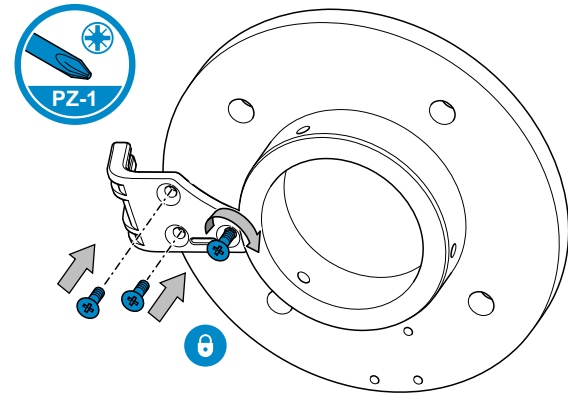

# Installation

2. Carefully insert the head mounting plate base into the top column tube section of the FE-165. Rotate the plate so that the cable management bracket is aligned with the main body cable clamp.

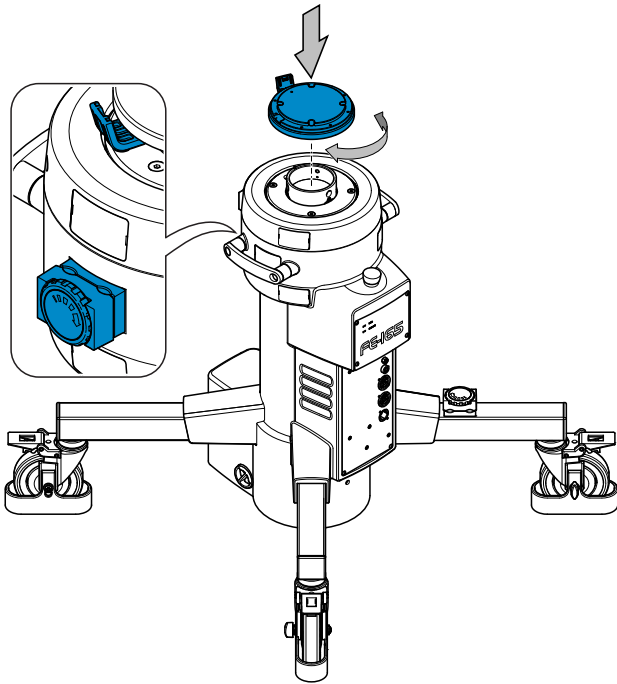

3. Fit the three countersink screws provided through the mounting holes in the side of the column. Tighten the screws fully to secure the head mounting plate in position.

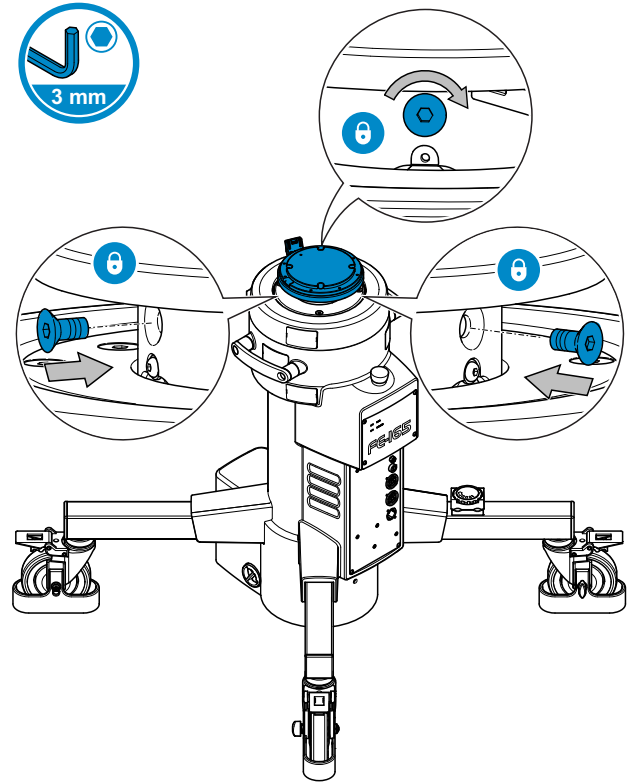

- 4. Carefully lower the robotic head onto the head mounting plate and rotate to align the mounting screw holes. Secure in position with the four head fixing bolts and washers provided.

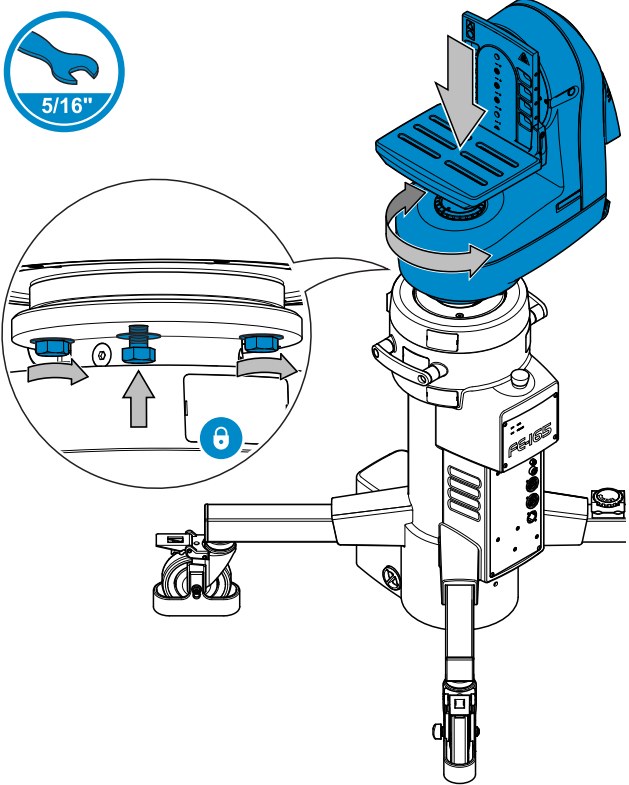

## Fitting the Camera and Accessories



**WARNING!** Before fitting equipment, refer to the installation instructions supplied with the robotic head, camera and any accessories. To ensure safe operation, the payload must be correctly balanced following installation.

When the robotic head has been secured to the FE-165, the camera, lens and any other accessories such as a prompter can be fitted.



**WARNING!** Ensure that all equipment being fitted has been correctly assessed. See the section **Payload Assessment** on page 14.

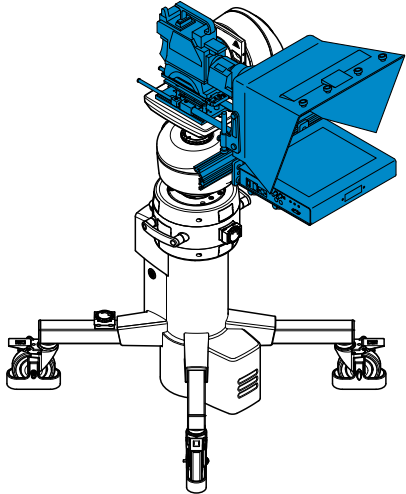
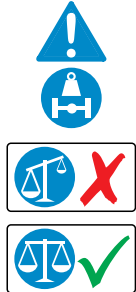

# Installation

## Fitting the Accessory Mounting Bracket (optional)

The optional accessory mounting bracket can be fitted so that a monitor can be mounted to the FE-165. The bracket is designed for use with the Autoscript Universal On-Air Mounting Bracket (p/no. MT-OA-UNI).

1. Remove the two capping screws from the front of the FE-165.

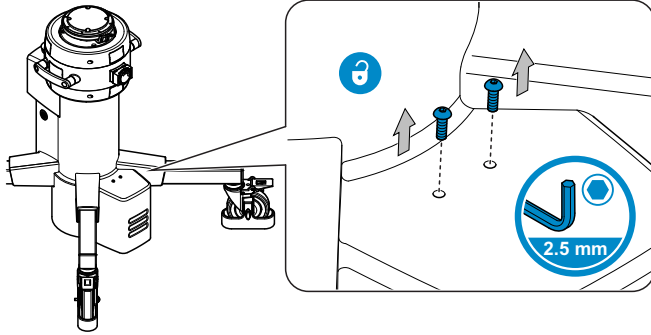

2. Align the accessory mounting plate with the two holes and secure in position with the countersink screws provided.

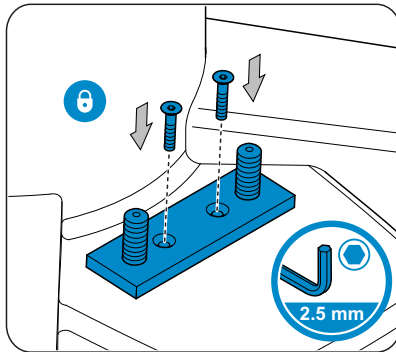

3. Lower the monitor mounting arm into position on the mounting plate, aligning the two holes with the mounting studs.

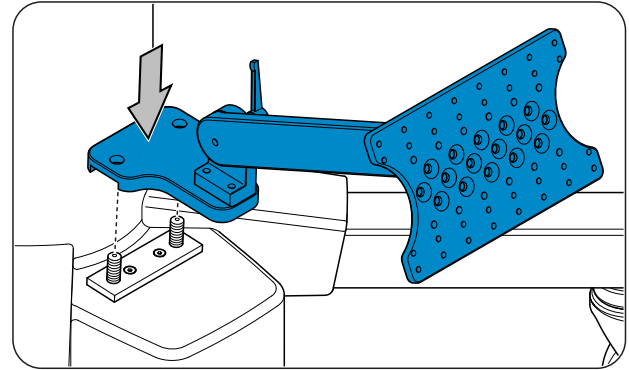

4. Fit the two threaded bosses supplied with the arm onto the mounting studs to secure in position.

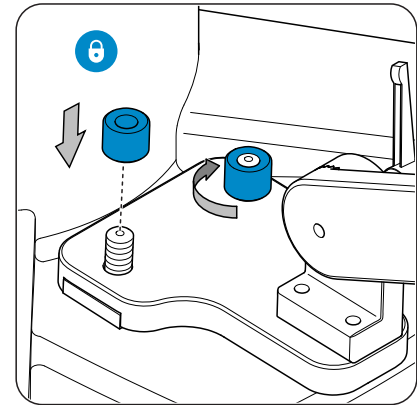

## 5. Attach the monitor to the monitor mounting arm.



**WARNING!** Ensure that the weight of the monitor does not exceed 4.5 kg (10 lb). When mounted and adjusted, ensure that the monitor does not protrude beyond the pivot points of the wheels.



**WARNING!** Only use recommended fixings that are capable of safely and securely holding the monitor in position. Refer to the user documentation supplied with the product.

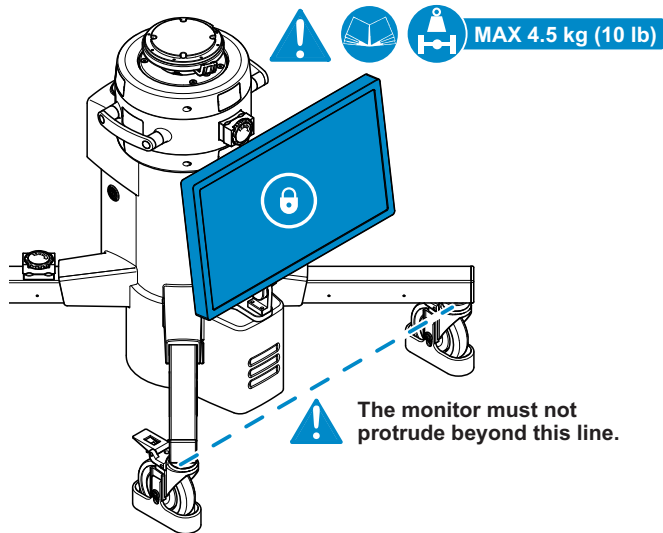

## Fitting the Elevation Controller (Elite Only)

The optional hand control can be fitted to a pan bar on the FH-145 robotic head.

1. Align the two parts of the elevation controller to fit on the pan bar near the handle grip.

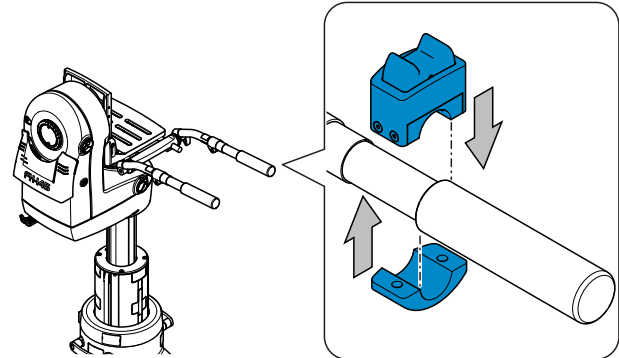

2. Secure the elevation controller in position with the two screws provided.

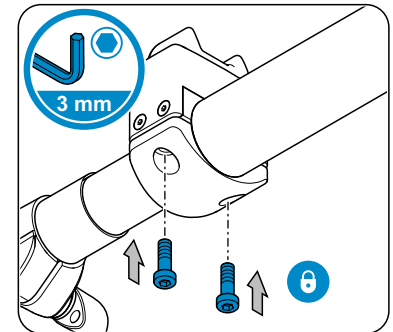

# Installation

## Connecting the FE-165

### System Connections

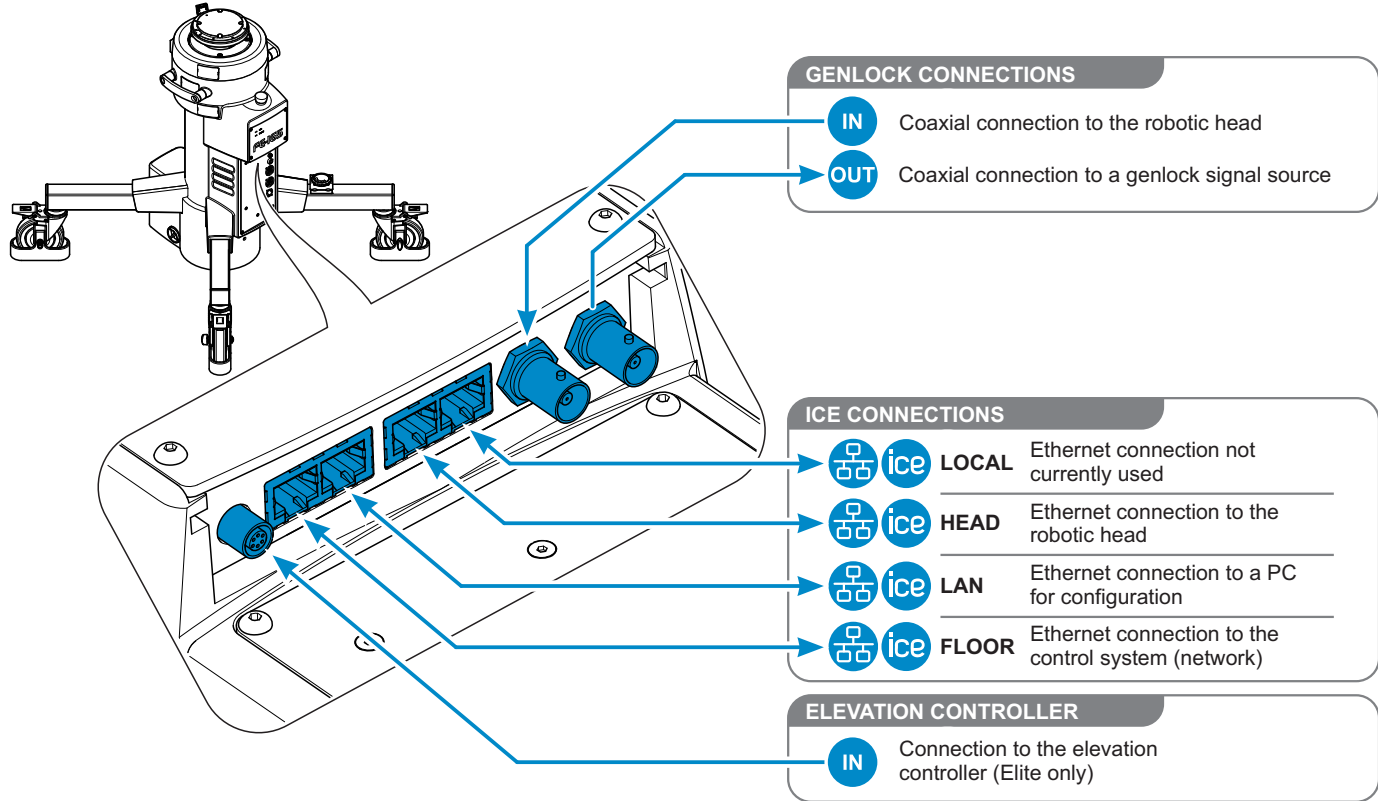

## Power Connections



**WARNING!** Only use the power supply cable supplied with the product. Do not exceed the current output limit of the product when powering auxiliary equipment.

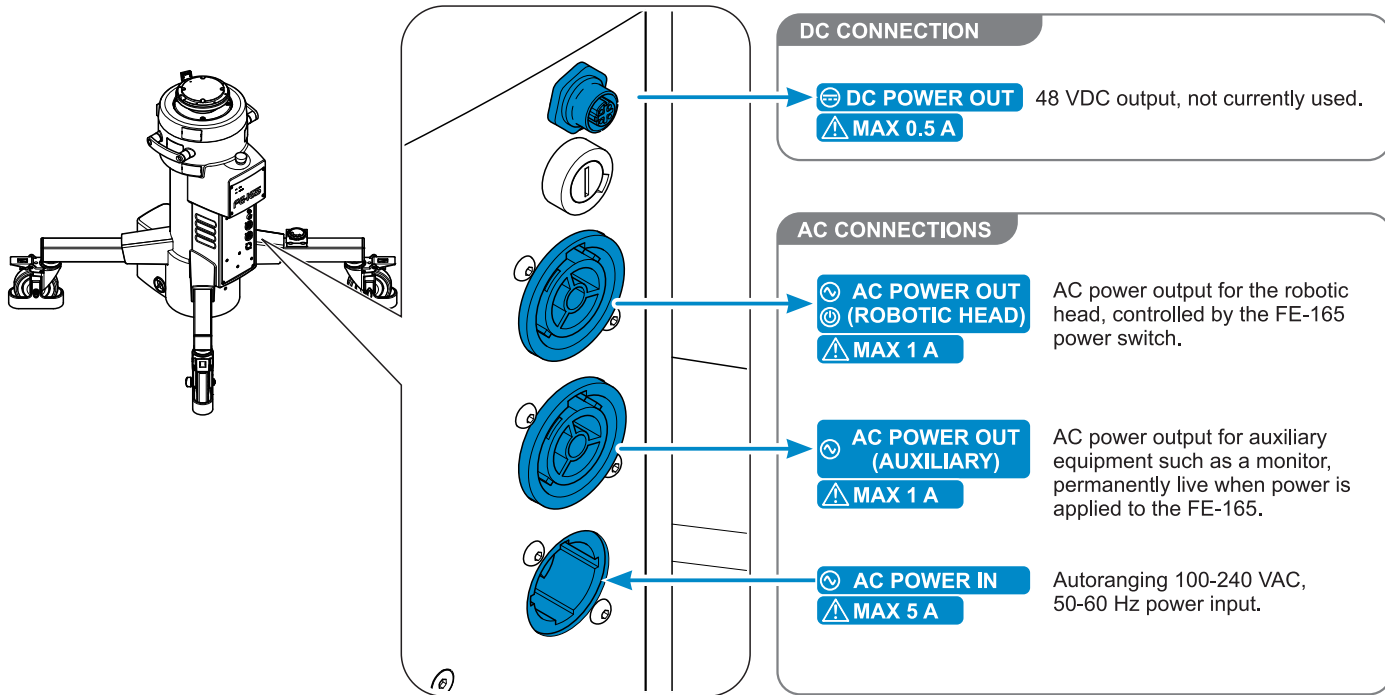

# Installation

## Cable Management

Following the completion of connections to the FE-165 and all the installed equipment, the associated cabling must be dressed into position and secured for safety. This is achieved by making use of the cable clamps and management brackets provided on the FE-165 and the robotic head. Cabling can be neatly secured, providing strain relief for the connectors and reducing the risk of cables becoming trapped or damaged.

### 1 Robotic Head to Mounting Plate\*

If the optional cable management bracket (Light only) has been fitted to the head mounting plate, attach all cabling as shown using cable ties. Provide a sufficient loop of slack in the cables so the robotic head can freely rotate through 360 degrees.

### 2 Column Top to FE-165 Body

Loosen the main body cable clamp knob sufficiently to feed the cabling from the head into the channels in the clamp block. To permit unrestricted and safe movement of the elevation column through its full stroke range, provide a minimum slack loop in the cabling between the head mounting plate and the main body clamp of **890 mm (35 in.)**. Do not over-tighten the cable clamp knob when securing the cabling.

### 3 FE-165 Body to Leg Clamp

Route the cabling through the leg clamp using the same method shown in step 2. Also route any additional cabling from the FE-55 connectors through the leg clamp.

### 4 Cable Dressing

Use additional cable ties to keep the cables together on long runs.

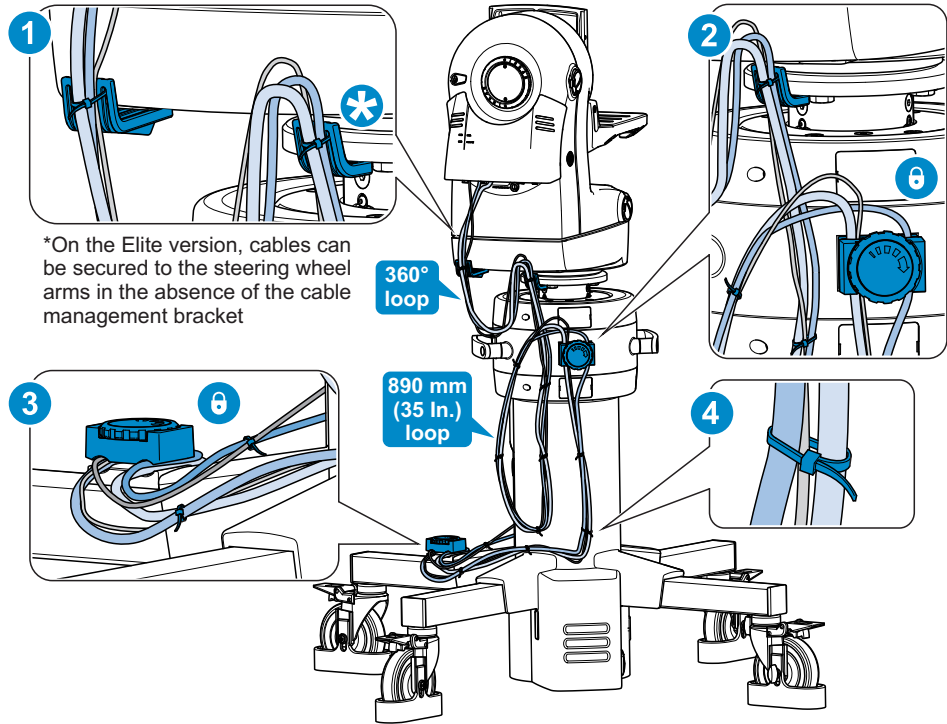



### Powering Up

Before powering up the FE-165, ensure that all external cable connections have been secured correctly.

To power up, press the power switch located on the side of the FE-165. The power switch will illuminate indicating that AC input power is present.

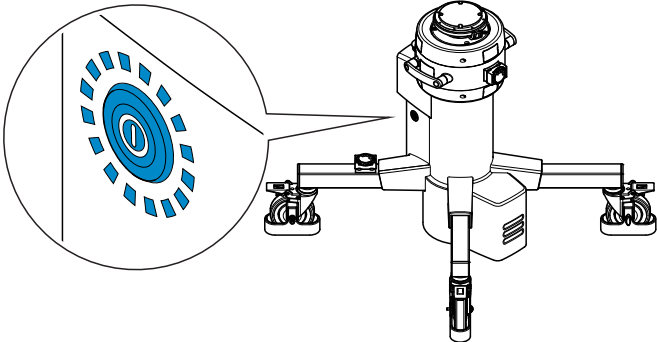

Power will also be present on the robotic head, supplied from the AC power out (robotic head) socket.

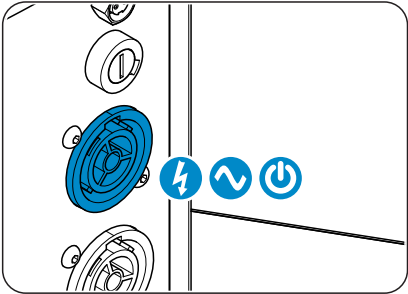

# Operation

## Operating the FE-165 - Safety Precautions



**WARNING! Risk of personal injury or injury to others.**  
When operating the product, strictly adhere to the safety precautions outlined in this section and the Safety section in the front of the user guide.



**WARNING!** Ensure that all personnel working with, or within the working area of the product, are fully trained and aware of all safety precautions associated with the product.

The FE-165 has been designed to incorporate important safety features such as the emergency stop button, column release knob and wheel brakes. Using these safety features correctly will reduce the risk of any potential safety hazards to an absolute minimum.

It is critical that all operators are trained in the handling and moving of the FE-165 to prevent the risk of the product toppling over when the elevation column is extended with a payload fitted.

### Moving the FE-165 or Adjusting the Payload



**WARNING!** Risk of product instability when moving the product with the elevation column fully extended. Reduce the height of the column before attempting to move the product.



**WARNING!** Before fitting, adjusting, or removing the payload, the elevation column must be lowered to a safe working height and the safety brakes must be applied.

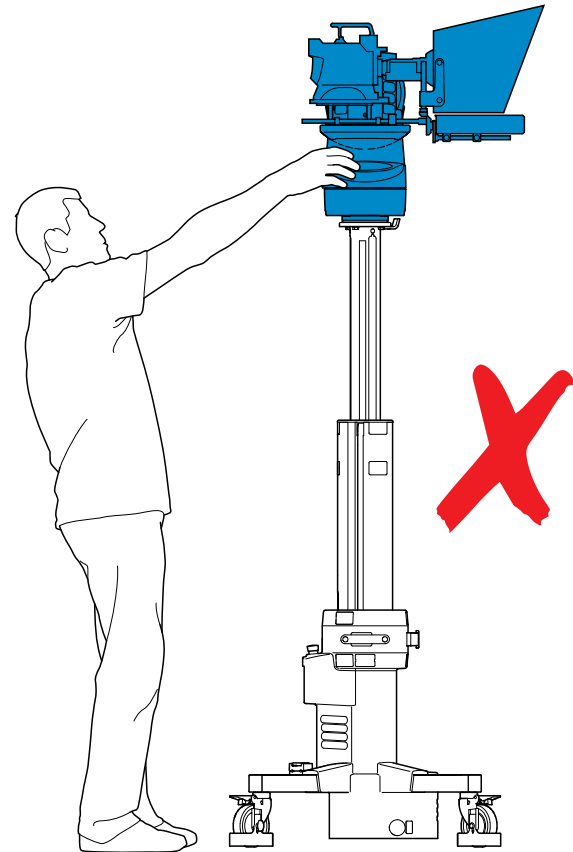

## Leaving the FE-165 Unattended



**WARNING!** The product must always be secured (all four wheel brakes applied) when left unattended. Do not leave the product unattended on a sloping surface.

For more information see the section **Installation** on page 14.

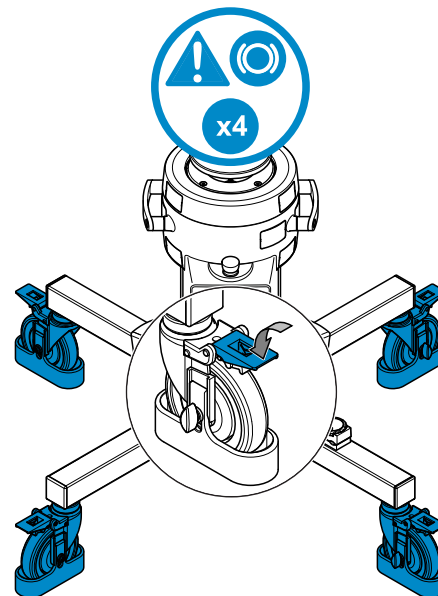
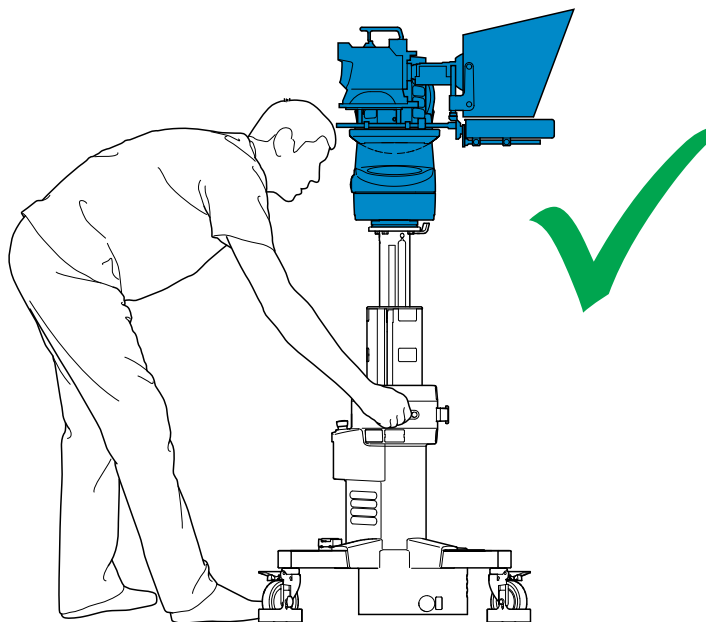

## Using the Emergency Stop Button



**WARNING!** All personnel working with, or within the working area of the product must be made aware of the location and function of the emergency stop button.

The emergency stop button is located above the indicator LEDs and connections panel.

If the emergency stop button is pressed, power to the FE-165 is immediately disconnected. This loss of power will also affect the robotic head connected to the AC power out (robotic head) socket.

To reset the emergency stop, twist and lift the stop button. Power will immediately be reinstated, but the FE-165 will need to be reset using the control system.

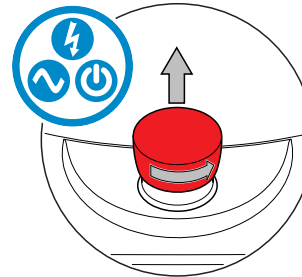
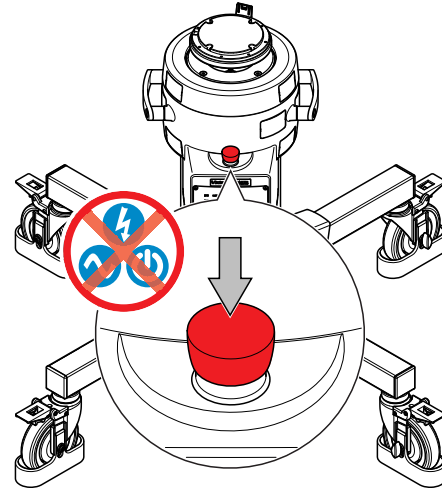

## Using the Column Release Knob

In the unlikely event of power loss or other modes of failure, coinciding with the elevation column being stuck in an extended position, the column release knob can be operated. This has the effect of disengaging the robotic drive and allowing the elevation column to be safely lowered, so that the FE-165 can be moved or the payload accessed.



**WARNING!** Isolate the FE-165 from the AC supply before operating the column release knob. Ensure that all four wheel brakes are applied.



**WARNING!** Two person operation. Do not attempt to lower the payload using the column release knob without the presence and assistance of another person.

1. Turn and hold the column release knob fully anti-clockwise to disengage the robotic drive.

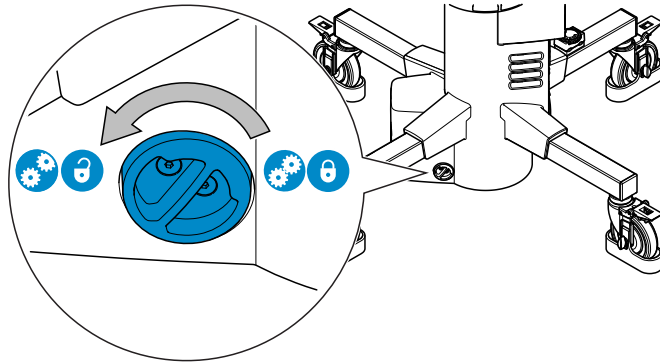

2. With the column release knob being held in the release mode position (A), the payload can be carefully lowered (B). Heavier payloads may slowly lower without the need for assistance.

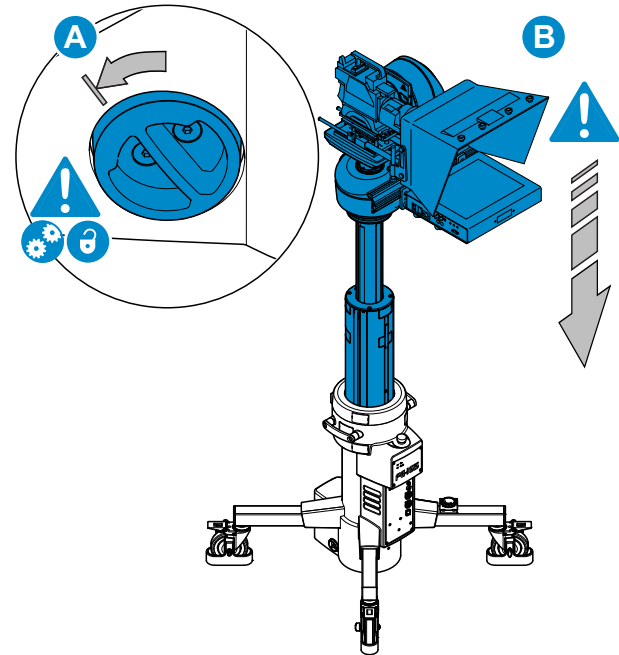

3. When the payload has been lowered to a safe working height, let go of the column release knob to automatically re-engage the robotic drive.

# Operation

## Manual Operation Mode (Elite Only)

Using the connected elevation controller, the FE-165 Elite elevation column can be operated locally.



Manual operation mode can only be used when an FH-145 robotic head is installed on the FE-165 Elite variant.

1. Place the pan and tilt axes of the FH-145 robotic head into manual mode.

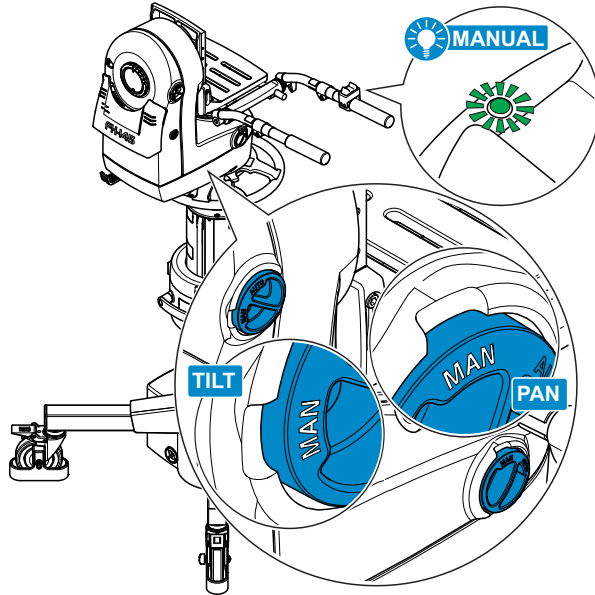

2. Use the rocker switch on the elevation controller to adjust the height of the column.

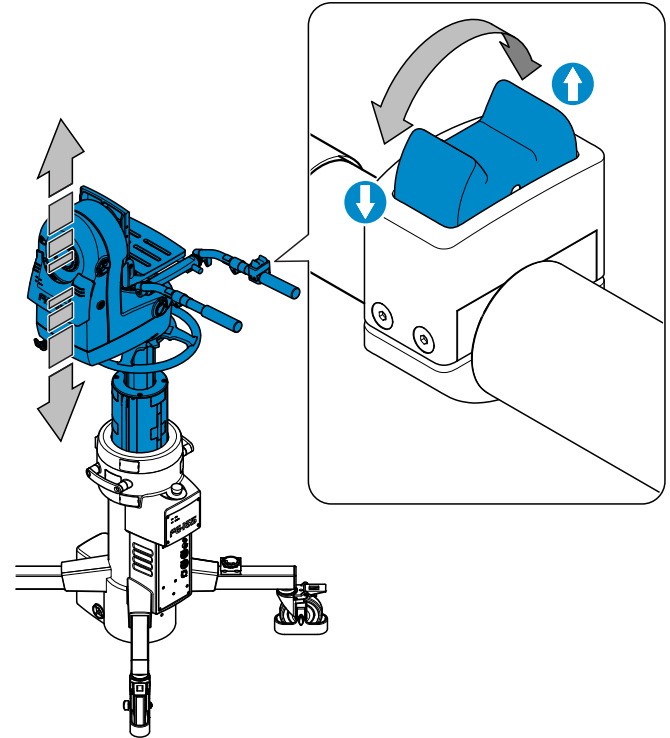

3. When manual mode is no longer required, use the control system to restore full remote robotic operation.

## Indicator LEDs

When the FE-165 is powered up, the indicator LEDs located at the top of the connections panel show whether data communications (green LED) or a genlock signal (amber LED) are present.

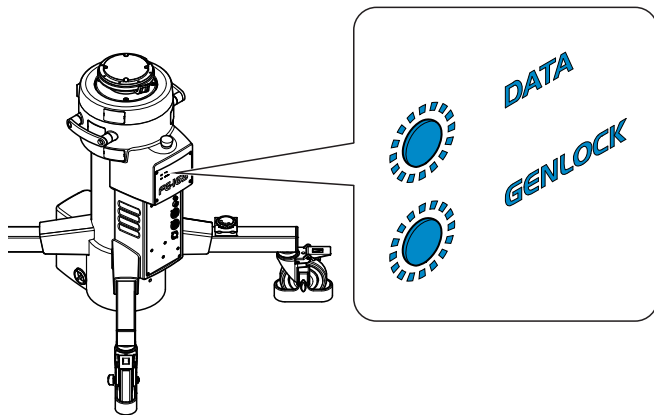

The indicator LEDs are also used to convey information about the current operational status of the FE-165, by displaying different solid or flashing colours.

	<b>Solid colours</b>
	<b>Flashing colours</b>
	<b>Bi-flashing colours</b>

The following table shows the indicator LED states which are potentially displayed during operation of the FE-165.

Data LED	Genlock LED	Status	Description
		<b>System Up</b>	The FE-165 is powered up and receiving data.
		<b>Robot Active</b>	The FE-165 and connected head are enabling or moving.
		<b>Identity</b>	The FE-165 has been selected by the control system and 'Identify' mode has been toggled on.
		<b>Manual Mode</b>	The FE-165 (FH-145) is in manual operation mode.
		<b>Genlock Connected</b>	A genlock signal is connected and active.

## Additional Indication Status

The indicator LEDs can also display error and warning status. Refer to the section **Maintenance** on page 32 for more information.

# Maintenance

## Routine Maintenance

The FE-165 requires minimal routine maintenance, apart from checking the connections and overall operation periodically.

### Routine checks

During use, check the following:

- Check that the payload is balanced and fully secured.
- Check cables for signs of wear or damage. Replace as necessary.
- Check that all cables are connected properly.

## Cleaning



**WARNING!** Disconnect and isolate the product from the power supply before cleaning.



**CAUTION!** Do NOT use oil or grease on any exposed part of the elevation column. This is unnecessary and traps dirt which acts as an abrasive.

During normal use the only cleaning required should be a regular wipe over with a dry, lint-free cloth. Dirt accumulated during storage or periods of disuse may be removed with a vacuum cleaner. Particular attention should be paid to all connection ports on the FE-165.

## Changing the Fuse



**WARNING! Risk of electric shock.** Disconnect the power cable. Fuses must only be changed by a trained and competent person.



**CAUTION!** The replacement fuse must be the correct type and rating: Type T5AH, 250V.

1. Switch OFF and disconnect the AC power source.
2. Using a flat-blade screwdriver or coin, rotate the fuse holder (a) anticlockwise and remove (b).

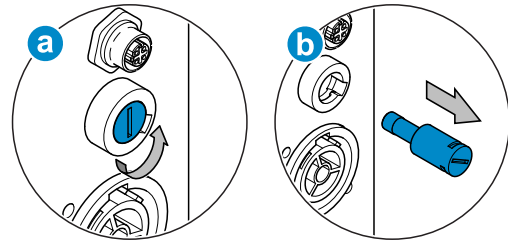

3. Replace the fuse and reinstall the fuse holder.

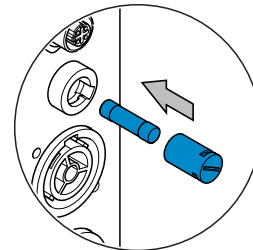



## Fitting the Leg Assemblies



**WARNING!** Only use the leg fixing screws and washers provided with the FE-165. Apply the torque settings shown when tightening the fixing screws.

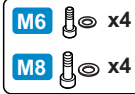

1. Tilt the FE-165 on it's side with the power switch facing upwards. Slide the leg assembly with the cable clamp into the leg housing closest to the power switch panel.

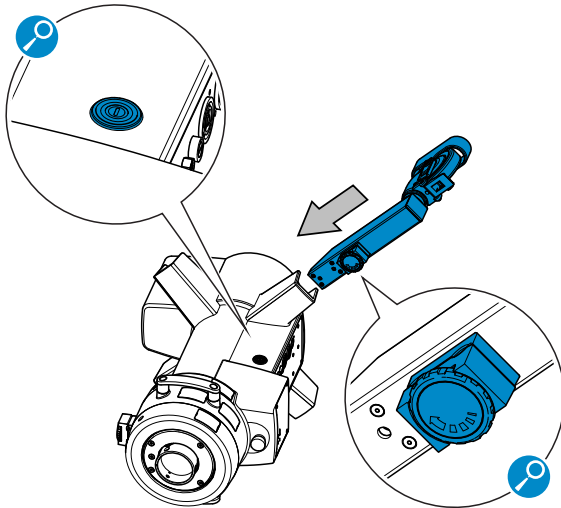

2. With the mounting holes aligned, fit one of the supplied M8 screws and washers as shown and tighten to the correct torque setting.

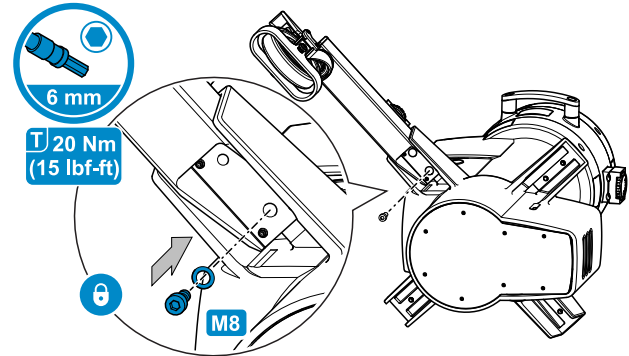

3. Fit one of the M6 screws and washers as shown and tighten to the correct torque setting.

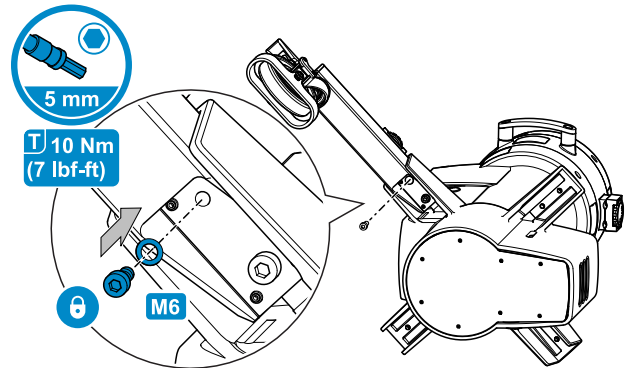

# Maintenance

4. With the FE-165 still tilted on the same side, fit one of the remaining three leg assemblies into the empty leg housing position. Secure the leg in position using the procedure shown in steps 2 and 3.

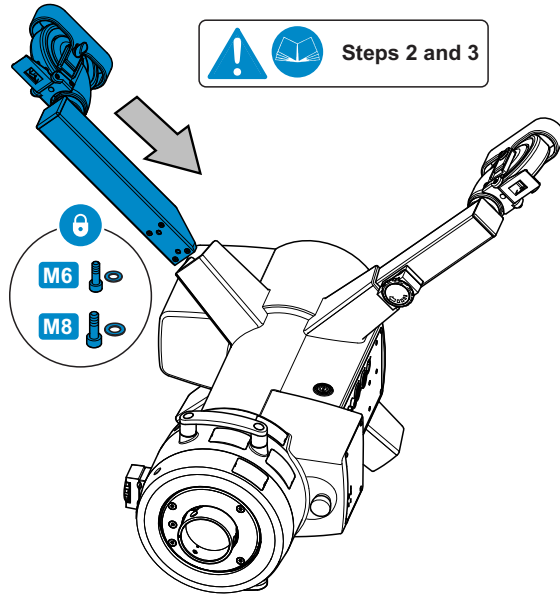

5. Carefully tilt the FE-165 over onto the two fitted leg assemblies. Fit the remaining two leg assemblies into the leg housings and secure them in position using the procedure shown in steps 2 and 3.

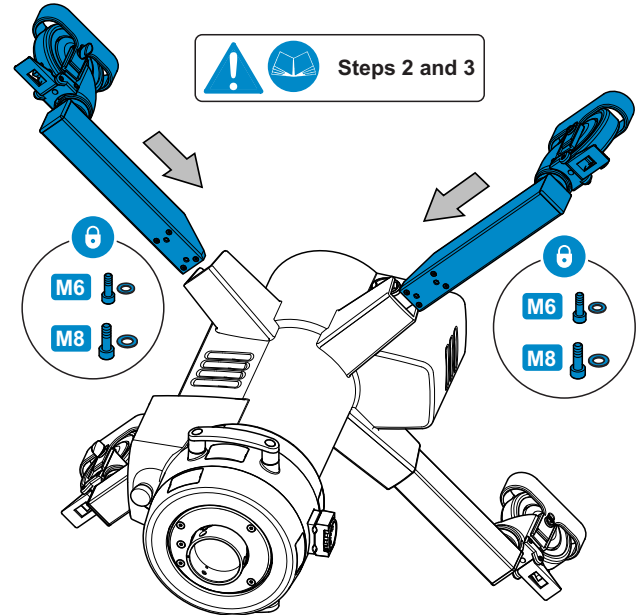



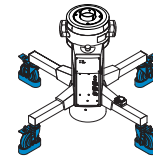

6. Carefully tilt the FE-165 back upright to rest on all four castor wheels.



Fault	Check	Comments
The FE-165 is not operating.	Check that the power switch is ON and illuminated.	See the section <b>Powering Up</b> on page 23.
	Check that the AC power source is connected and secured.	See the section <b>Power Connections</b> on page 21.
	Check that a network connection has been made with the Ethernet cable.	See the section <b>System Connections</b> on page 20.
The FE-165 is connected to the AC power source and switched on, but not operating and the power switch is not illuminated.	Check the fuse and replace as necessary with the correct type and rating.	See the section <b>Changing the Fuse</b> on page 30.
Intermittent or no communications with the FE-165.	Check the Ethernet cable. Check the Ethernet cable is CAT5E FTP.	If possible, try using another Ethernet cable.
The AC power source has failed or is unavailable and the elevation column is stuck in an elevated position.	Operate the column release knob to enable the elevation column to be safely lowered.	See the section <b>Using the Column Release Knob</b> on page 27.

## LED Indicators

Data LED	Genlock LED	Status	Comments
		<b>Factory Reset</b>	The FE-165 is currently being reset by the control system.
		<b>Error Detection</b>	<p>The emergency stop button may have been activated. See the section <b>Using the Emergency Stop Button</b> on page 26.</p> <p>The FE-165 has detected an error. Try power cycling the FE-165 and resetting using the control system.</p>

# Technical Specification

## Physical Data



**Minimum height**  
754 mm (29.7 in.)



**Width**  
800 mm (31.5 in.)



**Maximum height**  
1644 mm (64.7 in.)



**Length**  
800 mm (31.5 in.)



**Maximum payload**  
75 kg (165 lb)



**Ground clearance**  
25 mm (1 in.)



**Weight**  
50 kg (110.2 lb)



**Minimum door width**  
800 mm (31.5 in.)

## Operating Data



**On-shot stroke**  
890 mm (35 in.)



**Maximum column speed**  
150 mm/s (5.9 in./s)



**Minimum column speed**  
0.1 mm/s (0.004 in./s)



**Resolution**  
<0.014 mm (0.0005 in.)

## Electrical Data



**Supply voltage**  
Auto-ranging 100–240 VAC, 5 A, 50/60 Hz



**Power output socket (head)**  
100–240 VAC (supply voltage), 1 A



**Power output socket (auxiliary)**  
100–240 VAC (supply voltage), 1 A



**Fuse Type**  
T5AH 250 V

## Environmental Data



**Operating temperature range**  
+5°C to +40°C (41°F to +104°F)



**Storage temperature range**  
-20°C to +60°C (-4°F to +140°F)

## ETL Certification



## FCC Certification



## FCC Notice

This product complies with the limits for a Class B digital device, pursuant to Part 15 of the FCC Rules. These limits are designed to provide reasonable protection against harmful interference in a residential installation. This equipment generates, uses and can radiate radio frequency energy and, if not installed and used in accordance with the instructions, may cause harmful interference to radio or television reception, which can be determined by turning the equipment off and on. The user is encouraged to try to correct the interference by one or more of the following measures:

- Reorient or relocate the receiving antenna.
- Increase the separation between the equipment and receiver.

- Connect the equipment into an outlet on a circuit different from that to which the receiver is connected.
- Consult the dealer or an experienced radio/television technician for assistance.

## FCC Warning

Changes or modifications not expressly approved by the party responsible for compliance could void the user's authority to operate the equipment.

## FCC Declaration of Conformity

This product complies with Part 15 of the FCC Rules. Operation is subject to the following two conditions:

1. This product may not cause harmful interference.
2. This product must accept any interference received, including interference that may cause undesired operations.

## Declaration of Conformity



Videndum Limited declares that this product has been manufactured in accordance with BS EN ISO 9001:2008 and is in compliance with the essential requirements and other relevant provisions of the Machinery Directive 2006/42/EC. A copy of the Declaration of Conformity is available upon request.

## Environmental considerations

### European Union Waste of Electrical and Electronic Equipment (WEEE) Directive (2002/96/EC)



This symbol marked on the product or its packaging indicates that this product must not be disposed of with general household waste. In some countries or European Community regions separate collection systems have been set up to handle the recycling of electrical and electronic waste products. By ensuring this product is disposed of correctly, you will help prevent potentially negative consequences for the environment and human health. The recycling of materials helps conserve natural resources.

Visit our website for information on how to safely dispose of this product and its packaging.

### In countries outside the EU:

Dispose of this product at a collection point for the recycling of electrical and electronic equipment according to your local government regulations.

## Pollution statement

This equipment is designed for operation in Pollution Degree 2 environments.



