

# Operators Guide

## Vision 8

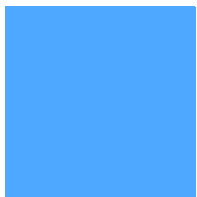

## Pan & Tilt Head

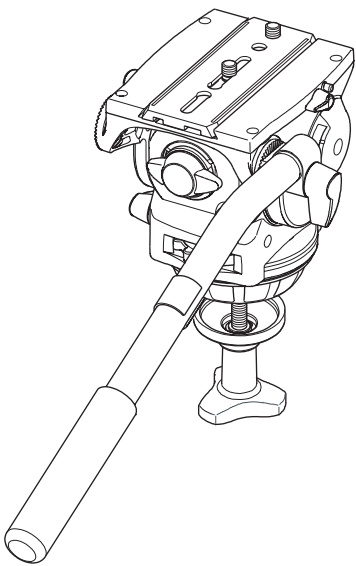

***Vinten***  
Camera Control Solutions

---

# **Vision 8**

## **Pan and Tilt Head**

**Publication Part No. 3441-8      Issue 4**

Copyright © Videndum Limited 2004

All rights reserved throughout the world. No part of this document may be stored in a retrieval system, transmitted, copied or reproduced in any way including, but not limited to, photocopy, photograph, magnetic or other record without the prior agreement and permission in writing of  
Videndum Limited.

Vinten and Vision are registered trademarks of Videndum Limited.

---

---

## Safety - read this first

### Warning Symbols in this Operators Guide



Where there is a risk of personal injury, injury to others, or damage to the pan and tilt head or associated equipment, comments appear, highlighted by the word **WARNING!** and supported by the warning triangle symbol.

## Technical data

Weight	
Head	2.7 kg (5.9 lb)
Pan bar	0.2 kg (0.4 lb)
Bowl clamp	0.14 kg (0.3 lb)
Height to mounting face	15 cm (5.9 in.)
Length	14 cm (5.5 in.)
Width	12.5 cm (4.9 in.)
Typical payload	10.5 kg (23 lb) - See balance graph
Tilt range	±90°
Pan range	360°
Tripod fixing	100 mm ball

## Further information

For further information or advice regarding this pan and tilt head, please contact Videndum Limited, your local Vinten distributor (see back cover) or visit our website.

For full details on maintenance and spare parts, please refer to the Vision 8 Pan and Tilt Head Maintenance Manual and Illustrated Parts List (Publication Part No. 3441-9) This is obtainable from Videndum Limited or your local Vinten distributor. For information on-line, visit our website at

**[www.vinten.com](http://www.vinten.com)**.

---

# Contents

	<b>Page</b>
<b>Safety - read this first</b> .....	3
<b>Technical data</b> .....	3
<b>Further information</b> .....	3
<b>Introduction</b> .....	7
<b>Operation</b>	
Installing the head on a tripod .....	9
Mounting the camera .....	9
Balancing the head .....	12
Pan and tilt brakes .....	14
Pan and tilt drag .....	14
<b>Servicing</b>	
Routine maintenance .....	15
Cleaning .....	15
Battery replacement .....	15
Brake knob and drag control knob adjustment .....	16
<b>Parts list</b> .....	17

## Associated publication

Vision 8 Pan and Tilt Head  
Maintenance Manual  
Publication Part No. 3441-9

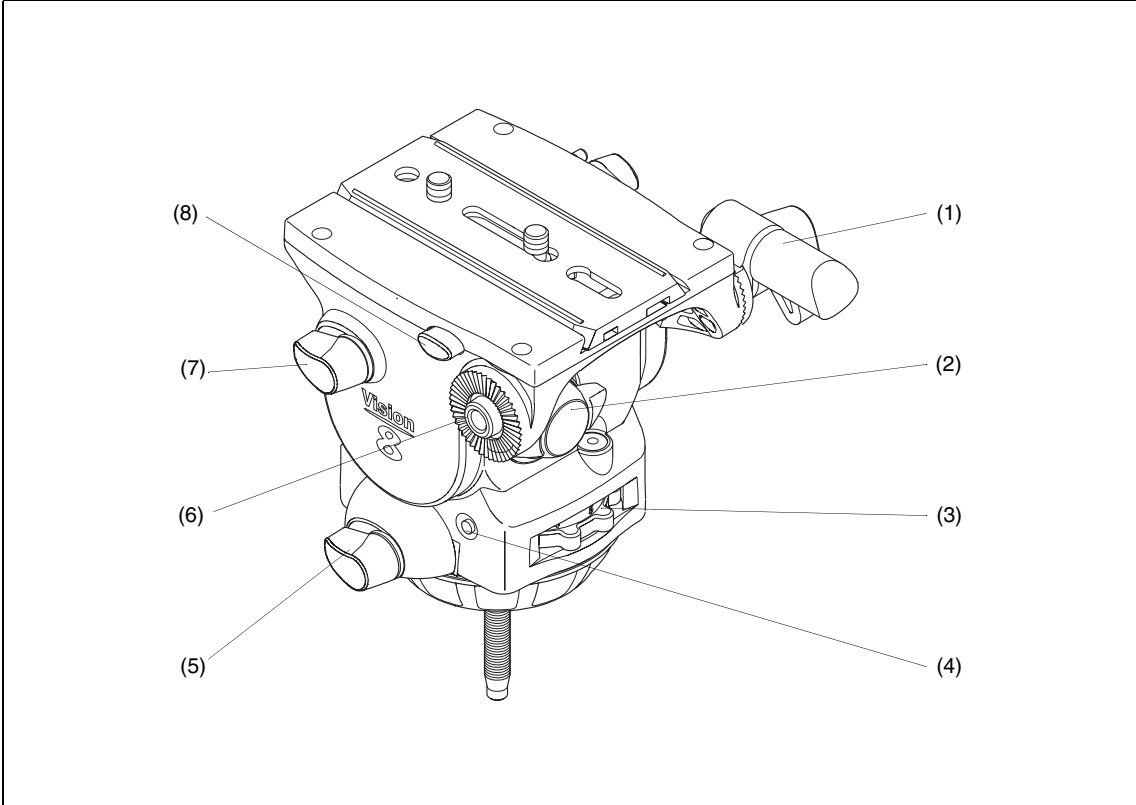

**Vision 8 (Left-Hand Side)**

- |     |                                     |
|-----|-------------------------------------|
| (1) | Pan bar                             |
| (2) | Balance knob                        |
| (3) | Pan drag adjustment knob            |
| (4) | Switch for illuminated level bubble |
| (5) | Pan brake knob                      |
| (6) | Pan bar mounting                    |
| (7) | Tilt brake knob                     |
| (8) | Slide lock release                  |

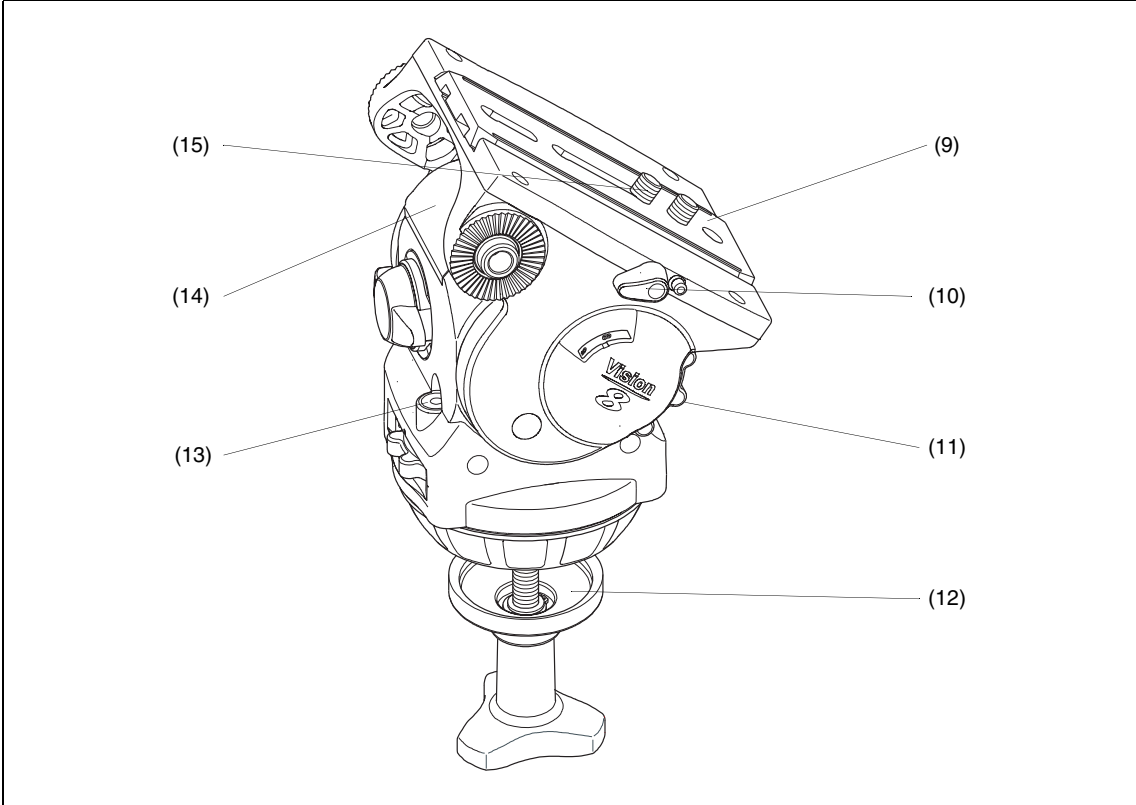

### Vision 8 (Right-Hand Side)

- |      |                           |
|------|---------------------------|
| (9)  | Slide plate               |
| (10) | Slide plate clamp         |
| (11) | Tilt drag adjustment knob |
| (12) | Bowl clamp                |
| (13) | Illuminated level bubble  |
| (14) | Battery compartment       |
| (15) | Camera mounting screws    |

---

## Introduction

The Vision 8 pan and tilt head embodies an adjustable spring counterbalancing mechanism, LF drag assemblies for pan and tilt motions and an adjustable camera mounting plate.

The balance system is easily adjusted by a knob (2) on the rear of the head. Maximum and minimum payloads that can be balanced, and tilt ranges, are dependent on the weight of the camera and accessories and on the centre of gravity (C of G) height.

The graph shows the range of load and C of G height that can be maintained in balance. The shaded area of graph corresponds to those load/C of G combinations that can be balanced over the full tilt range. The areas to the right indicate the progressively reducing tilt range with greater load and higher C of G.

Where a load/C of G combination falls outside of the graph it will be necessary to increase or decrease the weight or the C of G height - if possible - to enable the head to balance the load.

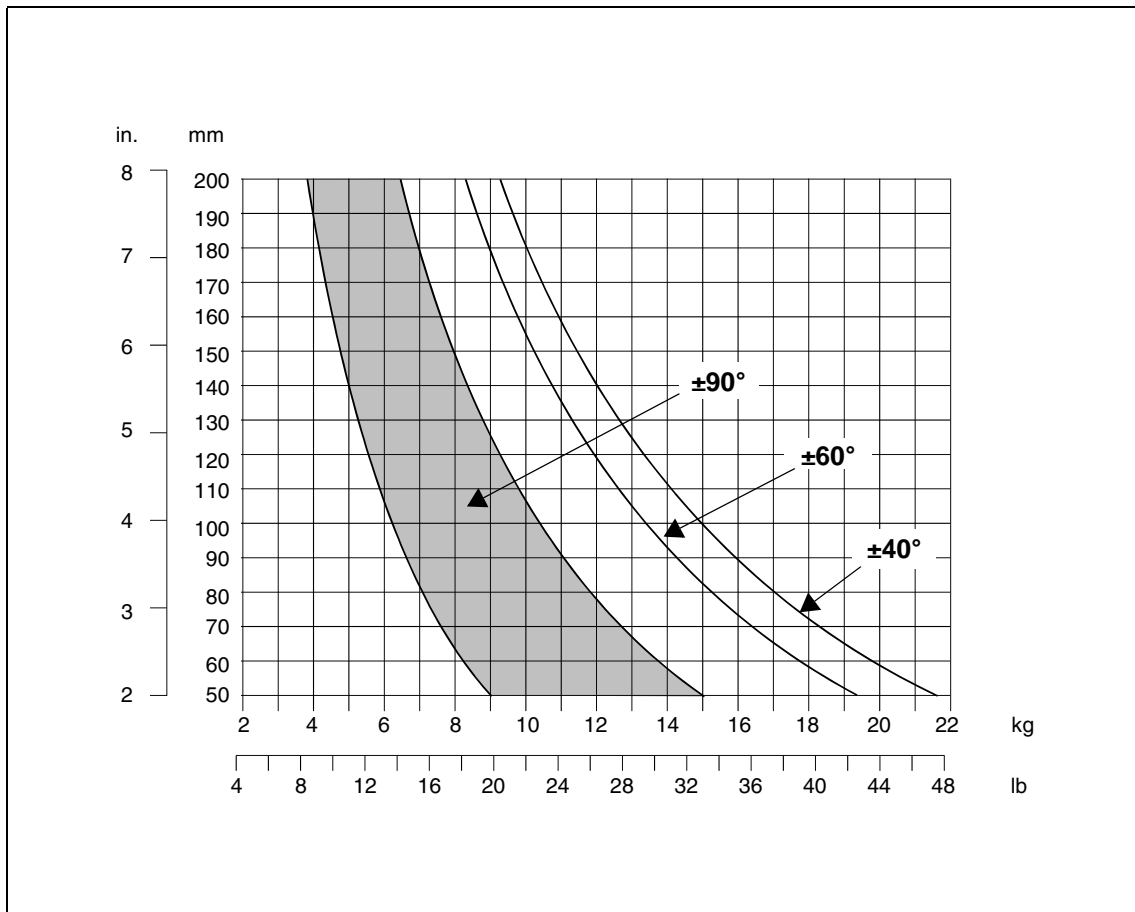

**Balance graph**

---

Both the pan and tilt mechanisms incorporate the patented Vinten lubricated friction (LF) system to ensure smooth movement of the camera about these axes and are fitted with control knobs (3, 11) to adjust the drag setting.

The whip-pan facility is unaffected by the pan drag setting.

Friction brakes on each axis allow the head to be locked at any chosen position. The operating knobs for both brakes (5, 7) are fitted at the left-hand side of the head.

An illuminated level bubble (13) is fitted to the rear of the head. When the switch (4) is pressed, the bubble will be illuminated for 15 seconds. The battery for the illuminated bubble is contained in a battery compartment (14).

Pan bar mounting points (6) are located at the rear of the head, on either side of the camera mounting platform. The pan bar is attached using a pan bar clamp, with angular adjustment available on the mount serrations. A fixed pan bar (1) is supplied. A second pan bar may be fitted.

The camera is attached to the head by means of a slide plate (9) or by using the optional Quickfit<sup>®</sup> adapter (see **Mounting the camera**). A clamp (10) is provided to hold the slide plate in position and a lock (8) prevents its inadvertent removal from the head.



---

# Operation

## Installing the head on a tripod

The Vision 8 pan and tilt head is supplied with an integral 100 mm ball mount, designed for installation on a compatible Vinten Vision tripod.

Adaptors are available which enable the head to be installed on tripods or pedestals fitted with other mountings. These are listed under 'Optional Accessories'.

To install the head, remove the bowl clamp assembly (12) from the head, position the head on the tripod and refit the bowl clamp assembly from below. Level the head with the aid of the level bubble (13) and tighten the bowl clamp. The level bubble may be illuminated by pressing the switch (4). The light will extinguish after approximately 15 seconds.

## Mounting the camera

### Mounting the camera(3/8 in. mounting screws)

Remove the slide plate (9) from the head by releasing the slide plate clamp (10), pressing the slide lock release (8) and pulling the plate out to the rear.

Attach the slide plate to the camera or camera mounting plate under the approximate centre of the camera's weight using both mounting screws (15).

Set the platform level and apply both the pan and tilt brakes (5, 7).

Push the slide plate and camera into the track in the platform, ensuring the slide lock release (8) snaps into position.

Balance the head (see **Balancing the head**).

### Mounting the camera (VHS adaptor)

The optional VHS adaptor (21) consists of a VHS pin and a 1/4 in. BSW camera mounting screw connected by a plastic link.

To mount the camera using the VHS adaptor, proceed as follows:

Remove the slide plate (9) from the head by releasing the slide plate clamp (10), pressing the slide lock release (8) and pulling the plate out to the rear.

Remove the two 3/8 in. BSW camera mounting screws (15) from the slide plate.

Position the VHS (21) adaptor in the longer slot in the slide plate, with the pin facing forwards. Screw the pin securely into the slide plate.

Secure the slide plate to the camera with the 1/4 in. BSW camera mounting screw, ensuring the pin engages in the hole in the camera.

Set the platform level and apply both the pan and tilt brakes (5, 7).

Push the slide plate and camera into the track in the platform, ensuring the slide lock release (8) snaps into position.

Balance the head (see **Balancing the head**).

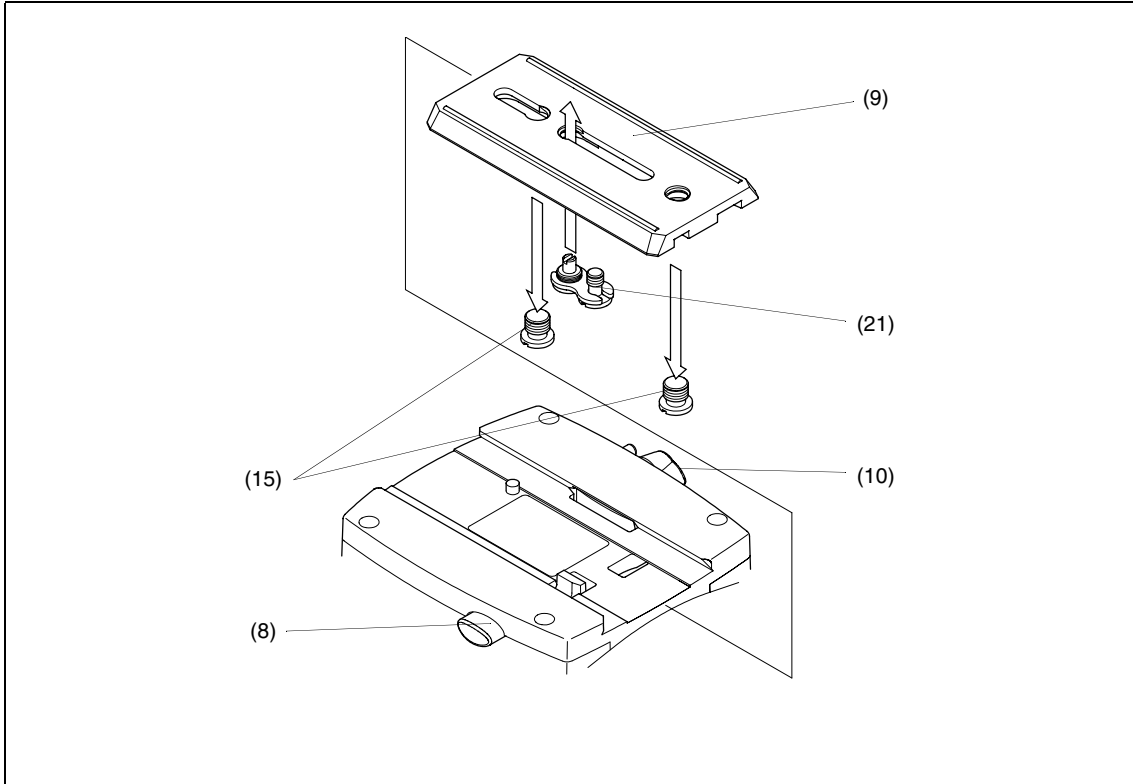

### Mounting the camera (VHS adaptor)

### Mounting the camera (optional Quickfit adaptor)

If not already attached, secure the Quickfit Adaptor (18) to the slide plate (9) with the two screws (15) provided.

Free the Quickfit wedge (17) from the adaptor by simultaneously pushing in on the safety catch (20) and operating the wedge release (19).

Fit the Quickfit wedge to the camera with the two screws (16) provided.

Insert the forward end of the wedge into the forward end of the adaptor. Lower the rear of the wedge into the adaptor until an audible click indicates that the wedge is locked in position.

Balance the head (see **Balancing the head**).

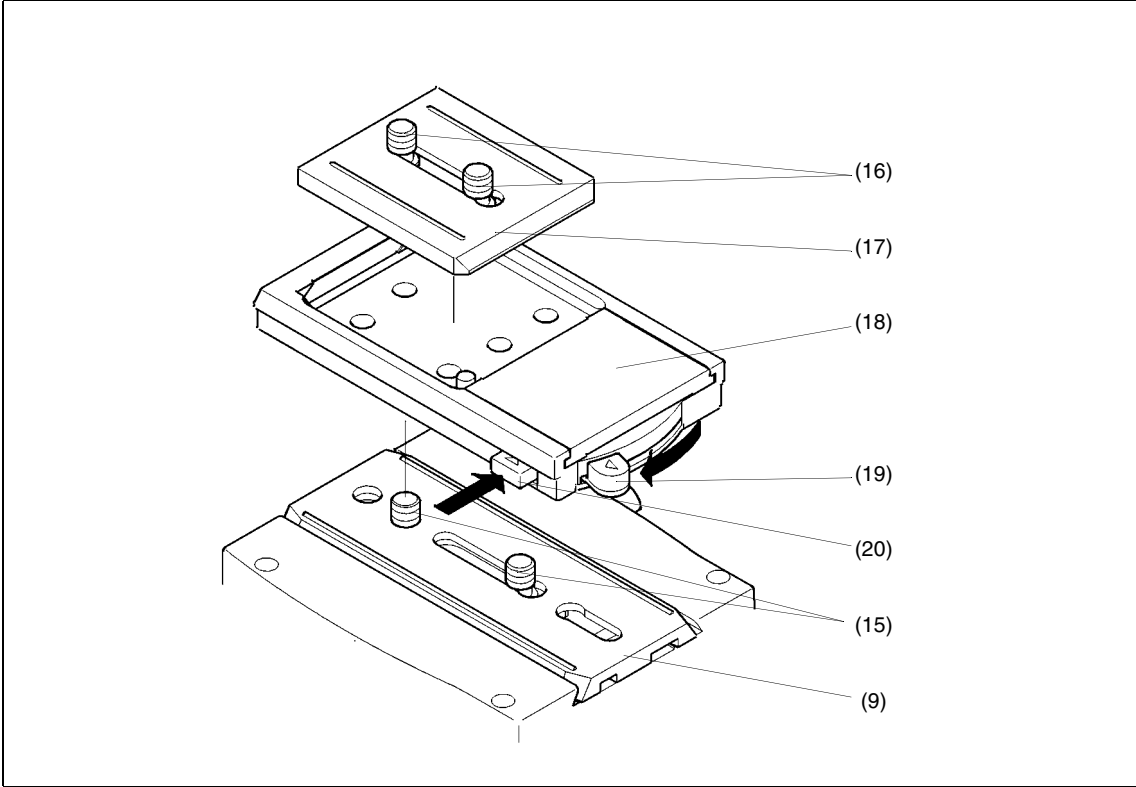

**Mounting the camera (optional Quickfit adaptor)**

---

## Balancing the head

Balancing a Vision head achieves two objectives. Firstly, when a head is correctly balanced the operator will need a minimum amount of even effort to move the head. Secondly, once balanced, the head and its payload can be set to any tilt position and the head will maintain this position with 'hands off'.

Prior to balancing the head ensure that the pan bars and any ancillary equipment have been fitted in order to prevent upsetting the balance once it has been achieved.



**WARNING! Be prepared to prevent the head falling away suddenly.**

---

---

1. Release the tilt brake (7). Turn the balance knob (2) counter-clockwise until the head falls away from horizontal under the weight of the camera.
  2. Release the slide plate clamp (10) and slide the camera backwards or forward until it balances horizontally. Apply the slide plate clamp (10).
  3. Turn the balance knob (2) clockwise until the camera does not fall away when the head is tilted and released.
  4. Repeat steps 2 and 3 until perfect balance is achieved, when the camera will remain set at any angle from +90° to -90° without falling away or springing back. Re-apply the tilt brake (7).
- 
- 

**NOTE:** Maximum tilt angle is less than 90° for heavy payloads with a high C of G - see balance graph (Fig 3).

---

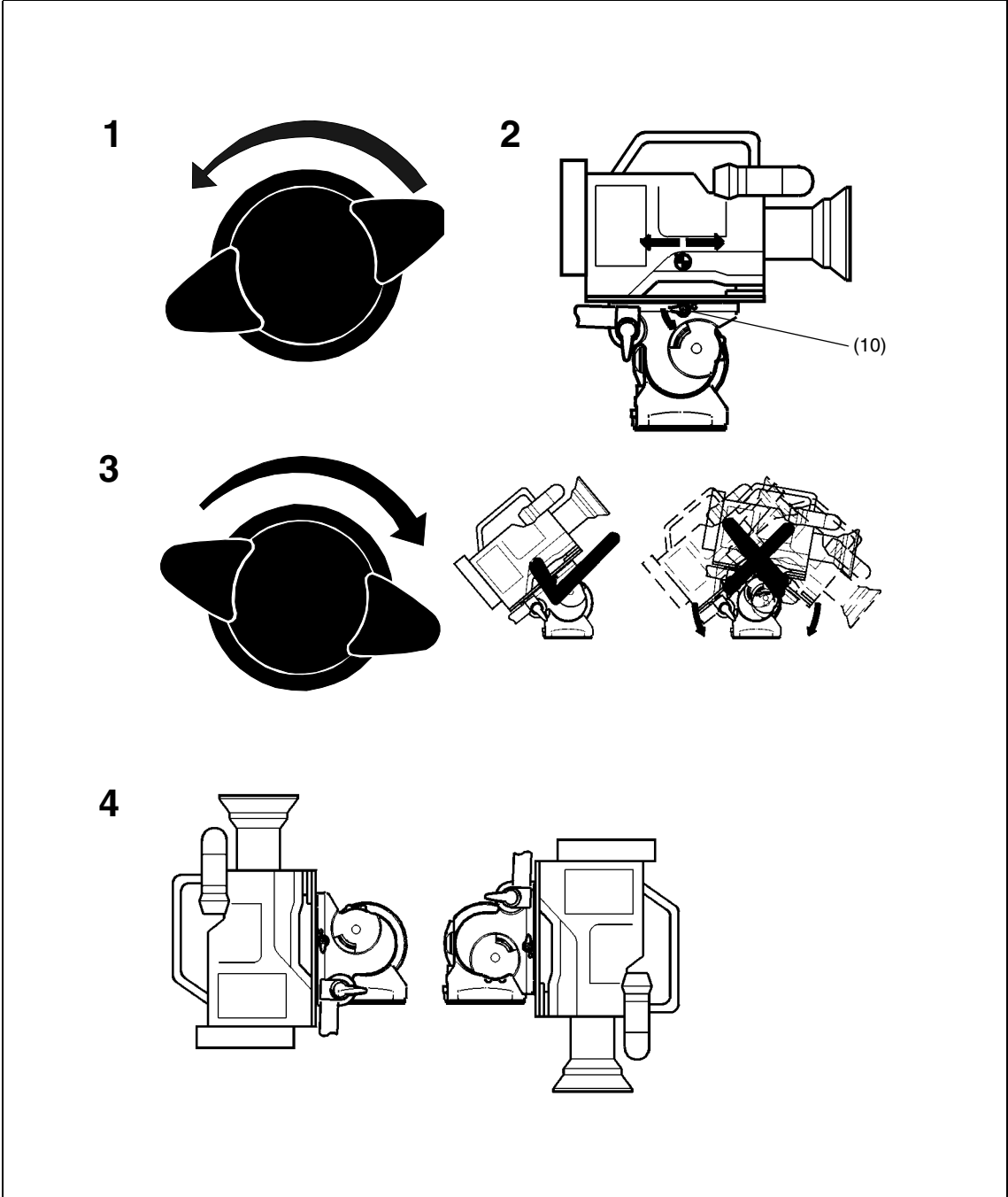

**Balancing the head**

---

## Pan and tilt brakes

Friction brakes on each axis allow the head to be locked at any chosen position. The operating levers for the pan brake (5) and tilt brake (7) are fitted at the left-hand side of the head.

To apply the brake, turn the lever fully clockwise. To release the brake, turn the lever fully counter-clockwise.



**WARNING! When the brakes are not in use, always turn the levers fully counter-clockwise.  
DO NOT use the brakes to supplement drag.**

---

---

## Pan and tilt drag

Both the pan and tilt mechanisms incorporate the Vinten LF system to ensure smooth movement of the camera about these axes and are fitted with control knobs to adjust the drag setting.

The pan drag adjustment knob (3) is rear of the head, the tilt drag knob (11) is on the right -hand side. The whip-pan facility is unaffected by the pan drag setting.

Both drag knobs are provided with graduated scales. To increase drag, turn the knob towards a higher graduation. To decrease drag, turn the knob towards a lower graduation.

---

**NOTE: Reduce drag to a minimum when the head is out of use for long periods.**

---

---

# Servicing

## Routine maintenance

During use, check the following:

Check the illumination of the level bubble. Replace battery if necessary.

Check the effectiveness of the pan and tilt drag controls. Reset as necessary.

Check the effectiveness of the pan and tilt brakes. Reset as necessary.

No further routine maintenance is required.

## Cleaning

During indoor use, the only cleaning required should be a regular wipe over with a lint-free cloth. Dirt accumulated during storage may be removed using a semi-stiff brush. Particular attention should be paid to the levelling bowl and mounting face of the head and to the space between the tilting assembly and the base.

All Vision heads are weatherproof. However, use out-of-doors under adverse conditions will require special attention. Salt spray should be washed off with fresh water at the earliest opportunity. Sand and dirt acts as an abrasive and should be removed using a semi-stiff brush or vacuum cleaner

---

**NOTE: Use only detergent-based cleaners. DO NOT use solvent- or oil-based cleaners, abrasives or wire brushes to remove accumulations of dirt, as these damage the protective surfaces.**

---

## Battery replacement

The battery illuminates the level bubble (13) when the switch (4) is pressed. The level bubble remains lit for approximately 15 seconds.

The battery should be replaced yearly or whenever the illumination is considered inadequate.



**WARNING! If a payload is not fitted to the head, turn the balance knob (2) fully counter-clockwise to reduce the balancing force before tilting the head forwards.**

---

---

To replace the battery:

Tilt the head forwards to allow access to the battery cover (14) and apply the tilt brake (7).

Using a thin-bladed screwdriver or similar tool, prise off the battery cover (14).

Pull out the battery (14.1) to the extent allowed by the cable and remove the connector (14.2).

Push the connector onto the terminals of the replacement battery.

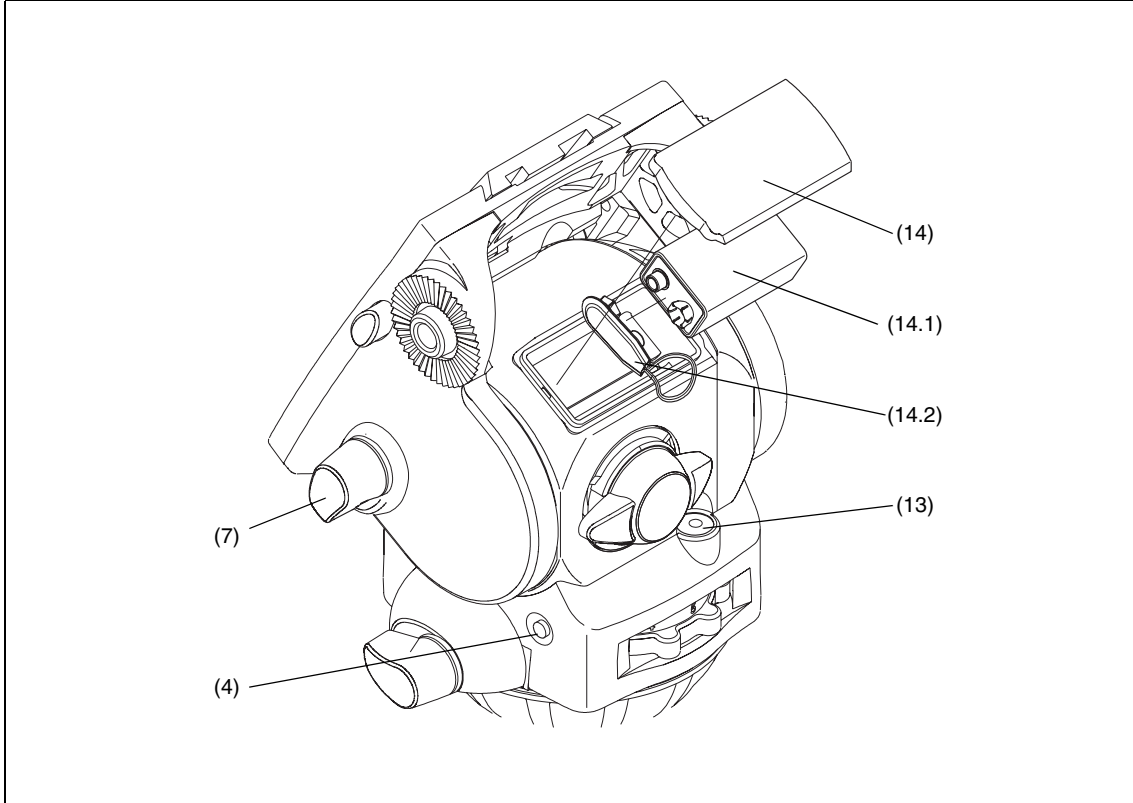

## Battery replacement

Position the battery in the battery compartment, ensuring that the wiring is neatly stowed in the cut-out provided.

Refit the battery cover (14).

Press the switch (4) and ensure that the level bubble (13) is lit for approximately 15 seconds.

## Brake knob and drag control knob adjustment

The pan and tilt brake and drag controls may require adjustment after prolonged use. These adjustments should be carried out by competent persons as detailed in the Maintenance Manual. The Maintenance Manual may be obtained from Videndum Limited or your local Vinten distributor or from our website at [www.vinten.com](http://www.vinten.com).



---

## Parts list

The following lists include main assemblies, user-replaceable spare parts and optional accessories. For further information regarding repair or spare parts, please contact Videndum Ltd or your local distributor.

For information on-line, visit our website at

**[www.vinten.com](http://www.vinten.com)**.

### **Main assemblies**

Vision 8 pan and tilt head - grey	3441-3
Vision 8 pan and tilt head - black	3841-3
Bowl clamp knob assembly	3330-30
Pan bar and clamp - grey	3219-71
Pan bar and clamp - black	3219-101
Camera mounting plate	3364-900SP

### **User-replaceable spare parts**

Brake knob kit	3431-900SP
Battery - 9V, 6LR61 (PP3, 6AM6, MN1604, E-BLOCK or equivalent)	C550-023

### **Optional accessories - Quickfit adaptors**

ENG Quickfit Automatic Adaptor (with wedge plate) - grey	3371-3
ENG Quickfit Automatic Adaptor (with wedge plate) - black	3471-3
Quickfit wedge	3763-11

### **Optional accessories - VHS adaptors**

VHS pin adaptor	3330-29
-----------------	---------

### **Optional accessories - tripod and pedestal adaptors**

100 mm ball to 4-hole flat base	3330-16
---------------------------------	---------