

Operators Guide

protouch

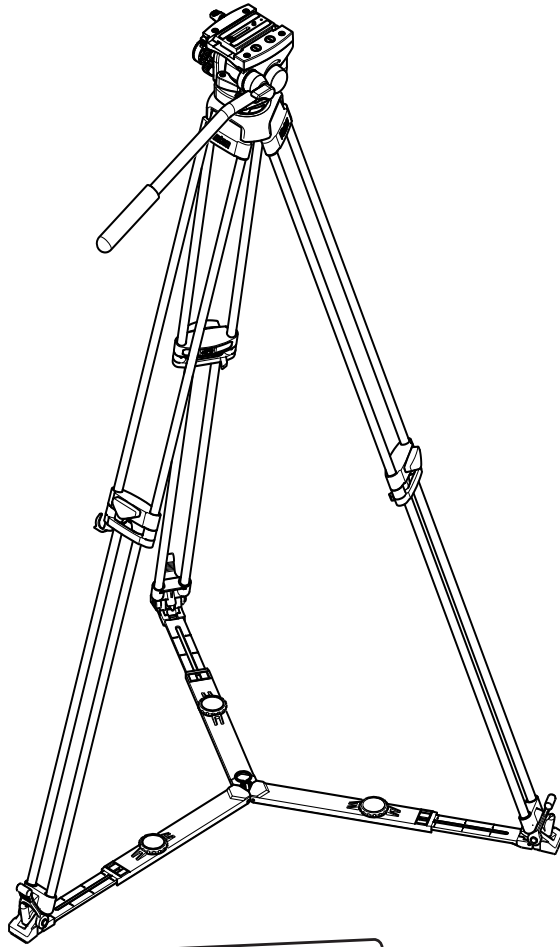

PRO-5^{Plus} System



Vinten
Camera Control Solutions

protouch

PRO-5^{Plus} System

Publication Part No. V4057-4980-EN
Issue 1

Original Instructions

Copyright © The Vitec Group plc 2009

All rights reserved throughout the world. No part of this document may be stored in a retrieval system, transmitted, copied or reproduced in any way including, but not limited to, photocopy, photograph, magnetic or other record without the prior agreement and permission in writing from the Vitec Group plc.

Vinten® is a registered trademark of The Vitec Group plc.



[Back](#)

Preface

Thank you and congratulations on your new Protouch PRO-5^{plus} system from Vinten

We want you to get the most from your new PRO-5^{plus} system, and therefore encourage you to read this operators guide to familiarize yourself with its many features, some of which may be new to you. It also covers essential health and safety information and a section on maintenance that will ensure you keep your new product in perfect condition.

To receive additional benefits, register with Vinten now on line by visiting www.vinten.com/register (see [Warranty Details and Terms and Conditions](#) on page 25).

Features and benefits of your new PRO-5^{plus} system

The PRO-5plus system is perfectly suited for all types of event videography using the latest generation of small format digital Camcorders and DSLR's.

- **0 to 4.5kg (9.9lb) @ 55mm C of G**
- **Two-step (zero and 1) spring counterbalance system for positive camera control.**
- **Top-loading 'Side Load' quick-release slide plate, with 1/4 in. and 3/8 in. camera screws and locating pin, accommodating the latest generation of digital Camcorders and DSLR's.**
- **Integral 75mm ball base for reliable levelling.**
- **Pozi-Loc tripod clamping system requires low effort with a 90° turn from on to off, providing the user with a positive indication that the tripod is securely locked.**
- **Single stage Aluminium Pozi-Loc tripod offering extensive height range, unrivalled torsional stiffness, rapid setup and convenient carrying.**
- **Protouch branded Petrol system case.**

Once again, thank you for choosing the PRO-5^{plus} system.

**We are confident it will give you many years of reliable
performance.**



Back

Safety - Read This First

Warning Symbols in this Operators Guide



Where there is a risk of personal injury or injury to others, comments appear highlighted by the word **WARNING!**—supported by the warning triangle symbol.

Where there is a risk of damage to the product, associated equipment, process or surroundings, comments appear highlighted by the word **CAUTION!**

Usage

The Pro-5^{plus} system is designed for event videography and the corporate sector to support and balance a camera and ancillary equipment weighing up to 4.5 kg (9.9 lb). The Pro-5^{plus} system is intended for use by professional camera operators.



WARNING!

1. **Do NOT attempt to use this product if you do not understand how to operate it.**
 2. **Do NOT use this product for any other purpose than that specified in the Usage statement above.**
 3. **Maintenance beyond that detailed in this Operators Guide must be performed only by competent personnel in accordance with the procedures specified in the Maintenance Manual.**
-
-

Further information

For full details on maintenance and spare parts, please refer to Protouch PRO-5^{plus} System - Maintenance Manual and Illustrated Parts List (Publication Part No. V4057-4990) This is obtainable from Vinten or your local Vinten distributor. For information on-line, visit our website at

www.vinten.com



[Back](#)

Technical specification

PRO-5^{plus} pan and tilt head

Weight:

Head with bowl clamp	1.65 kg (3.63 lb)
Pan bar	0.2 kg (0.44 lb)
Height to mounting face	11.2 cm (4.4 in.)
Length	12.1 cm (4.8 in.)
Width	15.3 cm (6.0 in.)
Load capacity (@ 55 mm centre of gravity)	4.5 kg (9.9 lb)
Counter balance	on/off
Tilt range	+90° -60°
Pan range	360°
Tripod fixing	75 mm ball
Operating temperature	-10°C to 60°C

Pozi-Loc tripod

Levelling bowl diameter	75 mm
Maximum height with floor spreader	156.2 cm (61.5 in.)
Minimum height with floor spreader	41.6 cm (16.4 in.)
Weight	3.2 kg (7.0 lb)
Transport length	71 cm (28.0 in.)
Recommended maximum load	25 kg (55 lb)

Floor spreader

Maximum leg radius	77 cm (22.5 in.)
Minimum leg radius	38 cm (15 in.)
Weight	0.7 kg (1.5 lb)



[Back](#)

Contents

	Page
Preface	3
Safety - Read This First	4
Technical specification	5
Usage	4
Further information	4
Introduction	
PRO-5plus pan and tilt head	11
Pozi-Loc tripod	12
Tripod spreader	12
Operation	
Mounting the camera	14
Checking camera balance	15
Pan and tilt brakes	17
Pan and tilt drag	17
Optional equipment	
Carrying strap	18
Dollies	18
Servicing	
General	20
Cleaning	20
Routine maintenance	20
Adjustments	21
Parts list	24
Warranty Details and Terms and Conditions	25

Associated publications

Protouch PRO-5^{plus} System - Maintenance Manual
Publication Part No. V4057-4990



Back

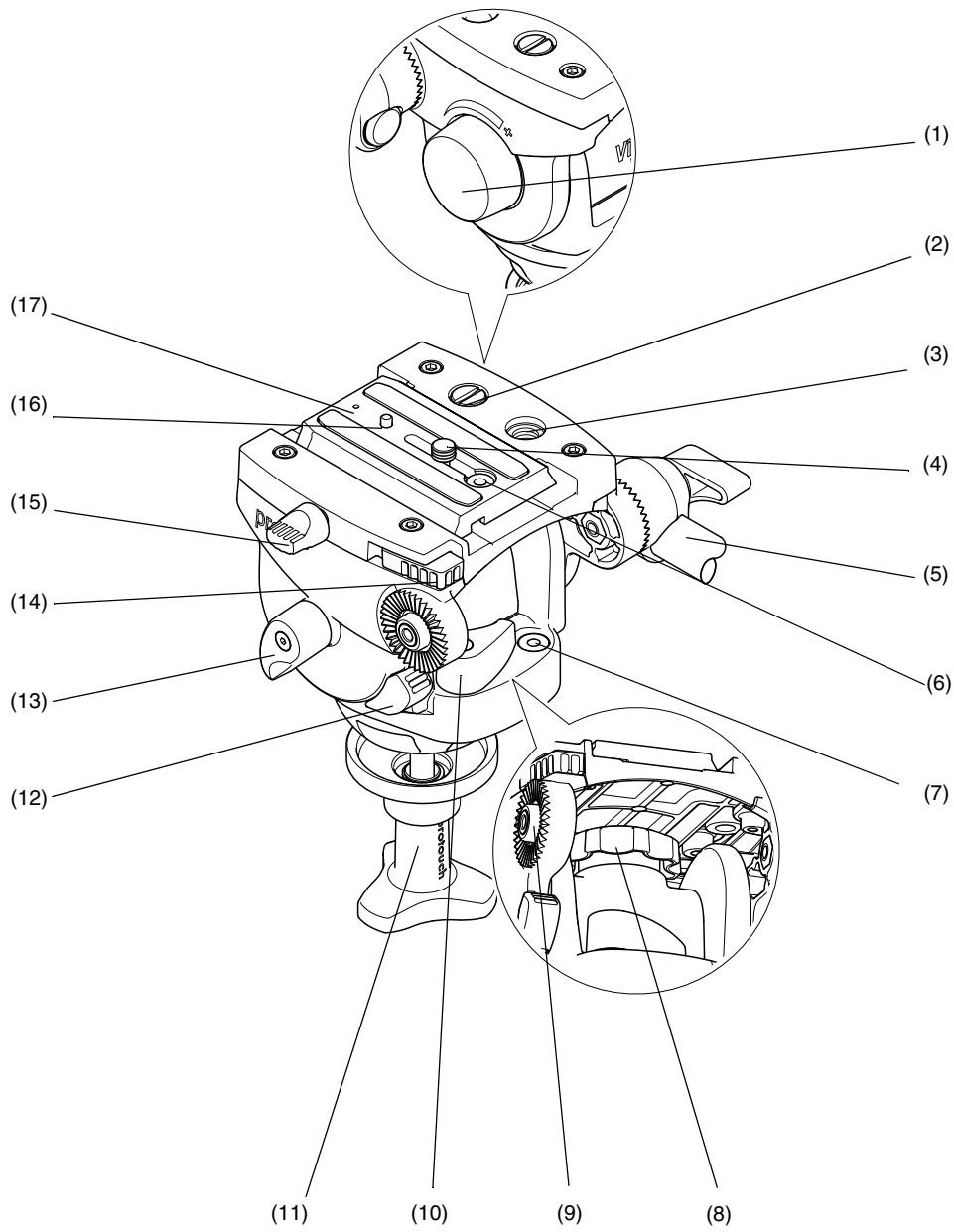

Fig. 1 PRO-5^{Plus} Pan and Tilt Head



[Back](#)

- (1) Tilt drag control
- (2) 1/4 in. camera screw
- (3) 3/8 in. camera screw stowage
- (4) 3/8 in. camera screw
- (5) Pan bar
- (6) Camera slide plate bung
- (7) Levelling bubble
- (8) Pan drag control
- (9) Pan bar mounting
- (10) Pan brake
- (11) Bowl clamp
- (12) Balance selector
- (13) Tilt brake
- (14) Camera slide plate release
- (15) Camera slide plate clamp
- (16) Locating pin
- (17) Camera slide plate



Back

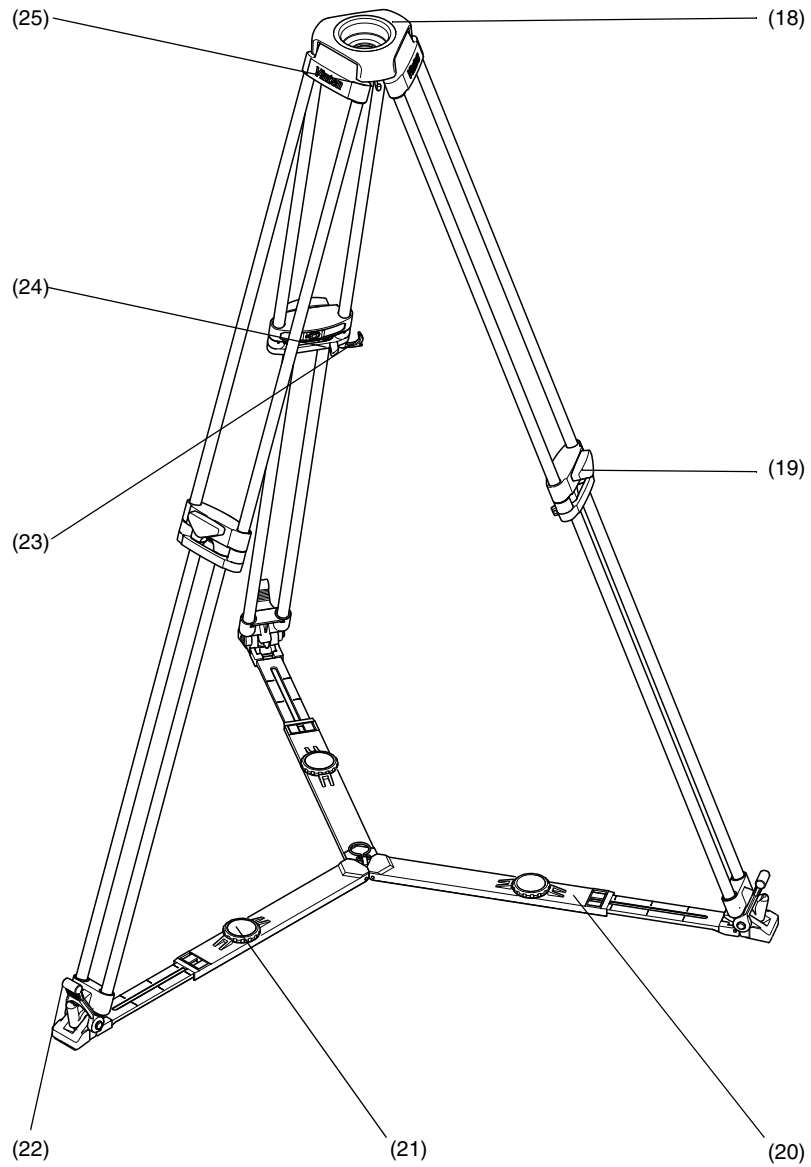

Fig. 2 Pozi-Loc Tripod and Floor Spreader



[Back](#)

- (18) Tripod bowl
- (19) Clamp knob
- (20) Floor spreader
- (21) Floor spreader adjuster
- (22) Foot securing strap
- (23) Leg tie strap
- (24) Attachment point for mid-level spreader
- (25) Tie down hook



[Back](#)

Introduction

The protouch PRO-5^{plus} system from Vinten comprises of a PRO-5^{plus} pan and tilt head, a Pozi-Loc single-stage tripod, a floor spreader and a soft case.

PRO-5^{plus} pan and tilt head

The PRO-5^{plus} pan and tilt head (Fig. 1) is designed to support the latest professional digital video cameras, up to 4.5 kg (9.9 lb) in weight. It embodies fluid drag assemblies for pan and tilt motions with brakes on each axis to lock the head in any position. A levelling bubble is fitted to the rear of the head and a quick-release, side-loading adjustable slide plate is provided for camera mounting. A single fixed pan bar is supplied.

Balance

The PRO-5^{plus} pan and tilt head's two-step balance system is set for payloads up to 4.5 kg (9.9 lb) at a centre of gravity (C of G) height of 55 mm (2.2 in.) or may be deselected for free tilt rotation. The graph (Fig. 4) shows the relationship between C of G height and payload for optimum performance.

Pan and tilt drag

Both the pan and tilt mechanisms incorporate fluid drag assemblies to ensure smooth movement of the camera about these axes and are fitted with control knobs (1) (8) to adjust the drag setting.

Pan and tilt brakes

Brakes (10) (13) on each axis are provided to lock the head in any position

Levelling bubble

To enable the head to be levelled, a levelling bubble (7) is fitted to the rear of the head.

Camera mounting

The camera is attached to the head by means of a slide plate (17), which is provided with a spring-loaded locating pin (16) and 1/4 in. (2) and 3/8 in. (4) screws. When not in use, the screws are stowed in the camera mounting platform (3). The slide plate (17) is loaded from above into the side-loading clamp mechanism, and a clamp (15) is provided to hold the slide plate in position. The release button (14) allows removal of the slide plate (17) from the head.

Pan bar

Pan bar mounting points (9) are located at the rear of the head, on either side of the camera mounting platform. The pan bar (5) is attached using a pan bar clamp, with angular adjustment available on the mount serrations. A single fixed pan bar (5) is supplied. A second pan bar may be fitted.



[Back](#)

Pozi-Loc tripod

The Pozi-Loc single-stage tripod (Fig. 2) has aluminium legs and a 75 mm levelling bowl (18). It is fitted with the highly-efficient Pozi-Loc leg clamp (19), which provides quick set-up and easy adjustment.

Tripod spreader

The tripod is supplied with a floor spreader (Fig. 2) which increases the rigidity of the tripod. The floor spreader which, being flexible, compensates for uneven ground, protects floors and carpets and prevents the tripod legs sinking into soft ground. It should be used at all times.

Each arm of the spreader is adjustable for length (21) and the tripod feet are secured by rubber straps (22). At the fullest extension of the spreader, and with all tripod legs fully retracted, the tripod can be used at its lowest operating height.



WARNING!

Do NOT use the tripod without a spreader to obtain a lower height, the tripod geometry will become unstable.

NOTE: The spreader may be removed and the tripod fitted to a dolly.



Back

Operation

Assembly

If not already done, assemble the system as follows:

Tripod and floor spreader

To install the floor spreader (Fig. 2):

Lift the tripod out of the case using the finger holes just below the top clamps.

Release the leg tie strap (23) and spread the legs.

Secure the spreader to the tripod feet with the rubber straps (22).

NOTE: Once assembled, keep the spreader attached to the tripod.

To adjust the tripod:

Adjust the operating height by undoing the leg clamps (19) and pulling the tripod up to the desired height. Adjust the spreader (21) if necessary.

Tighten the clamps (19) until an audible click is heard and the knob is in the horizontal, locked position.

In adverse conditions secure the tripod using the tie-down hook (25), or suspend a weight from the hook.



WARNING!

1. Always set the floor spreader to the widest practicable setting to increase stability. Use care when the tripod is fully extended and the floor spreader is in the closed position, as stability will be reduced.
 2. Do NOT hang items on pan bar handles (5). This will severely reduce tripod stability.
 3. Use care when setting the tripod on uneven surfaces, particularly stairs—stability will be reduced. Using a mid-level spreader is recommended on stairs (see [Optional accessories](#) on page 24).
 4. Secure the tripod using the tie-down hook (25) if the tripod is mounted in an elevated position above personnel—such as a platform or gantry.
-
-



Pan and tilt head

The PRO-5^{plus} pan and tilt head (Fig. 1) is supplied with a 75 mm ball mount. Adaptors are available which enable the head to be installed on tripods or pedestals fitted with other mountings. These are listed under [Optional accessories](#).

To install the head, remove the bowl clamp assembly (11) from the head, position the head on the tripod and refit the bowl clamp assembly from below. Level the head with the aid of the level bubble (7) and tighten the bowl clamp (11).

Mounting the camera

Remove the slide plate (17) from the head by releasing the slide plate clamp (15), pressing the slide lock release (14) and lifting the plate upward.

Install the required camera fixing screw (2) or (4) in the slide plate and retain with the rubber bung (6). Stow the unused screw in the appropriate stowage (3) in the platform.

Attach the slide plate (17) to the camera or camera mounting plate approximately under the centre of the camera's weight using the fixing screw (2) or (4) and locating pin (16) (if appropriate).

Set the platform level and apply both the pan (10) and tilt brakes (13).

Lower the camera onto the platform (Fig. 3) ensuring that the edge of the slide plate opposite the slide clamp engages first, and then push downward so the slide clamp 'snaps' into position.

Tighten the slide plate clamp (15).

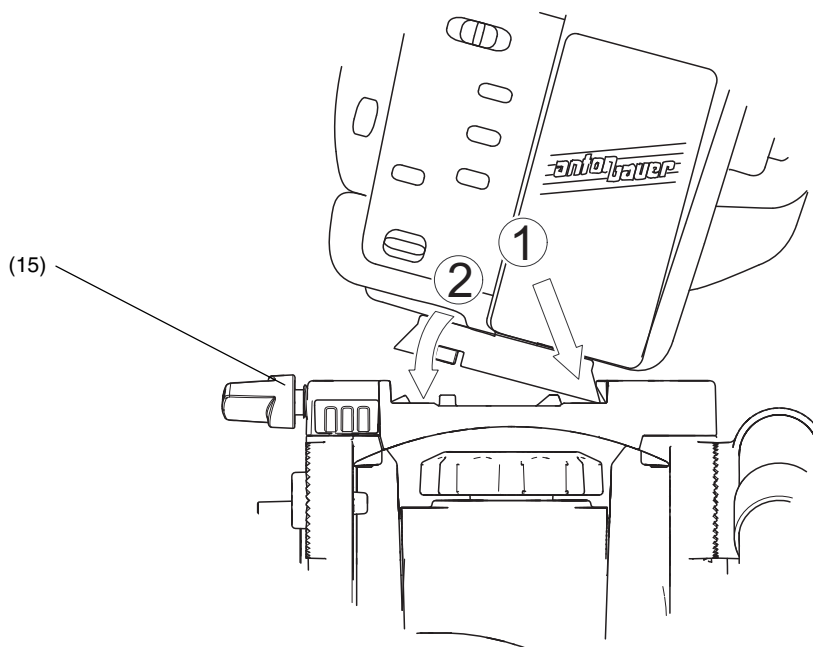

Fig. 3 Mounting the camera



Back

Checking camera balance

The PRO-5plus head has an on/off selectable balance system, set for payloads of 4.5kg (9.9lb) at a centre of gravity (C of G) height of 55 mm (2.2 in.). The graph (Fig. 4) shows the relationship between C of G height and payload for optimum performance.

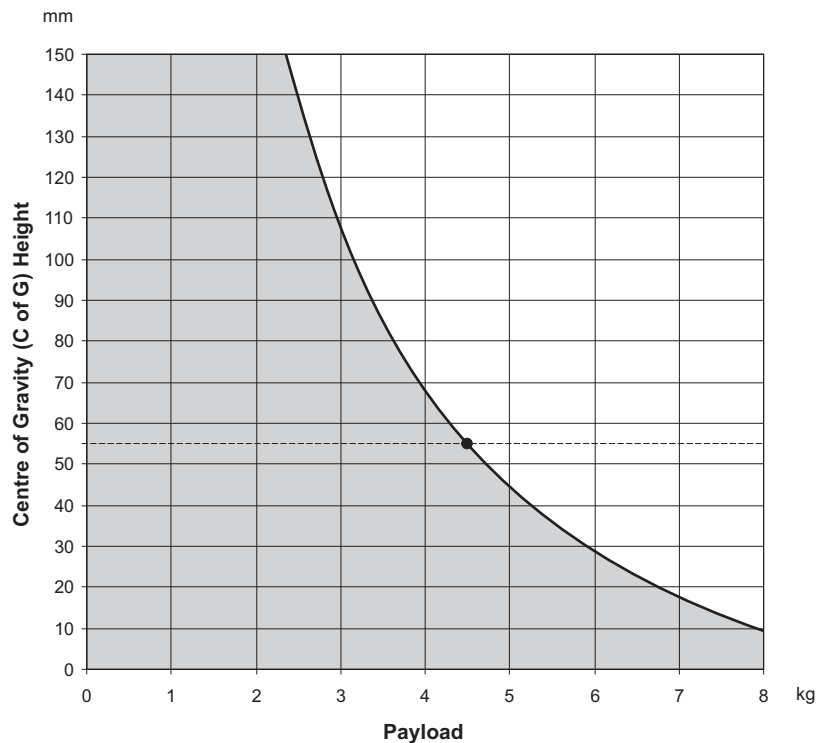

Fig. 4 Balance graph

The balance selector (12) allows two balance levels to be utilized. Pushing the selector (12) downward (Fig. 5) offers free rotation of the tilt axis with no counter-balance engagement. Lifting the selector (12) upward (Fig. 5) offers full balance capacity (Fig. 4).



WARNING!

1. Do NOT exceed the maximum capacity of either the head or the tripod. The system will become unstable and may fail.
2. Always support the camera payload if disengaging the counter-balance mechanism to prevent it falling away suddenly.
3. Keep hands clear of the moving platform to avoid trapping fingers.



Back

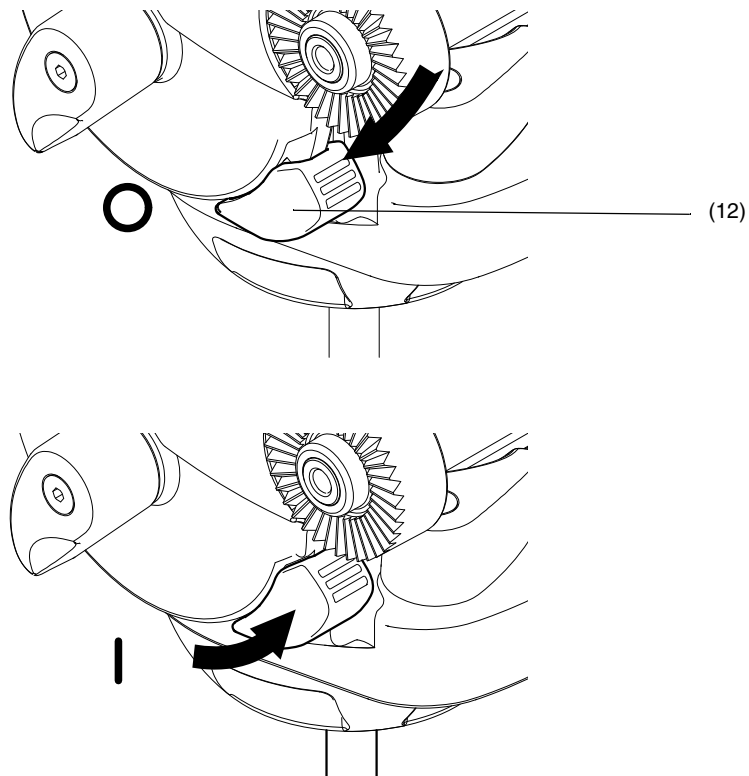

Fig. 5 Balance selector

Check the camera balance as follows, ensuring that the pan bar(s) (5) and any ancillary equipment have been fitted:

Reduce tilt drag (1) to minimum level.

NOTE: When changed, the selected balance level (12) engages as the platform moves through the horizontal position.



WARNING!
Steady the camera payload using the pan bar. Be prepared to prevent the head falling away suddenly. Keep hands clear of the moving platform to avoid trapping fingers.

Release the tilt brake (13).

Using the pan bar (5), tilt the head backwards and forwards to determine if the camera position is equally balanced in both directions. If not, set the platform level and apply the tilt brake (13). Position the camera correctly on the head by releasing the slide plate clamp (15)



Back

and sliding the camera backwards or forward until it balances horizontally. Apply the slide plate clamp (15). Re-check and adjust as necessary.

Using the pan bar (5), tilt the head backwards and forwards. If the head tends to spring back, de-select the balance system (12) and apply sufficient tilt drag (1) to control camera tilt as required. If the head tends to fall away, the payload exceeds the capacity of the head (Fig. 4). If possible, reduce the C of G height of any ancillary equipment or remove completely.



WARNING!
Securely apply the slide plate clamp (15) when balance has been achieved, to prevent the camera payload slipping.

Pan and tilt brakes

Brakes on each axis allow the head to be locked at any chosen position. The operating lever for the pan brake (10) is at the rear of the head. The tilt brake (13) is operated by a lever on the left-hand side of the head.

To apply the pan brake, turn the lever (10) fully clockwise. To release the brake, turn the lever counter-clockwise.

To apply the tilt brake, turn the lever (13) fully clockwise. To release the brake, turn the lever counter-clockwise.

CAUTION! DO NOT use the brakes to supplement drag, the head may be damaged. When the brakes are not in use, always ensure they are fully released.

Pan and tilt drag

Both the pan and tilt mechanisms incorporate a fluid drag system to ensure smooth movement of the camera about these axes.

The tilt drag adjustment knob (1) is on the left-hand side of the head, the pan drag knob (8) is on the top of the body, beneath the platform.

To increase drag, turn the appropriate knob clockwise. To decrease drag, turn the knob counter-clockwise.

CAUTION! Reduce drag to a minimum when the head is out of use for long periods, to minimize wear on drag components.



[Back](#)

Optional equipment

Carrying strap

A carrying strap (26) is available as an optional accessory and is installed as follows (Fig. 6):

On the lower moulding of the leg with the strap, drive in the 'knock-out' (23.1) using a suitable tool. If possible, remove the blank from inside the moulding to prevent subsequent rattle.

Push a blind captive nut (26.4) into the hole in the lower moulding.

Using a suitable M5 screw, fully compress the blind captive nut. Remove the M5 screw.

Install a washer (26.3) on the lower strap anchor (26.2) and screw into the captive nut (26.4). Ensure that the hole in the strap anchor is oriented so that the karabiner (26.1) can be attached.

On the underside of the tripod bowl (18), remove and discard the screw (26.5) securing the corresponding leg clamp (18.2). Do not remove the washer (18.1).

Position the bowl strap anchor (26.6) on the leg clamp, ensuring it is correctly oriented. Using Loctite 221, secure the bowl strap anchor (26.6) with the 25 mm M6 screw (26.5) supplied with the strap. Tighten screw to a torque of 4.5 Nm (40 lbf in.).

Using the karabiners (26.1), clip the strap (26) to the strap anchors and adjust to length.

Dollies

The PRO-5^{plus} system may be mounted on a variety of OB and studio dollies, which are listed under [Optional accessories](#) on page 24.



Back

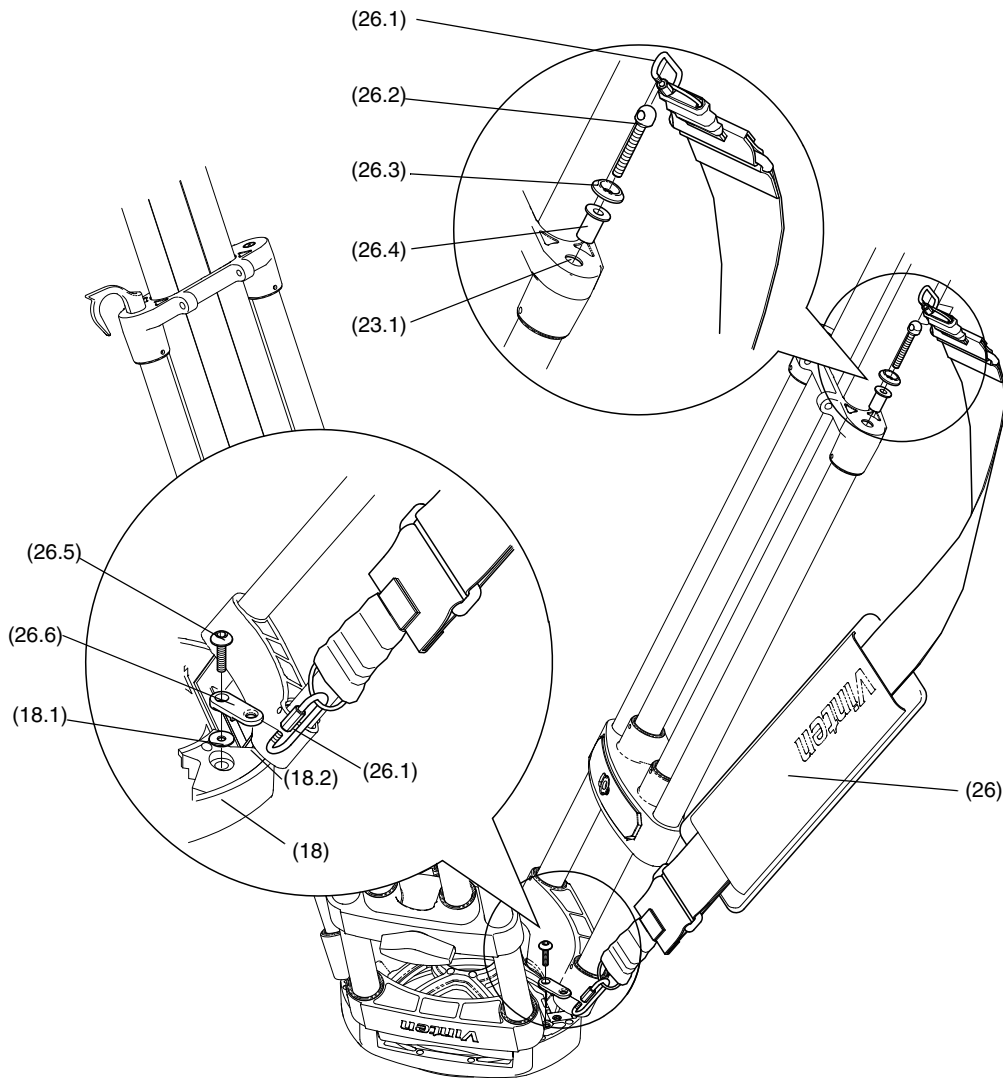

Fig. 6 Carrying strap



[Back](#)

Servicing

General

Protouch products are robustly made to high engineering standards and little attention is required to maintain serviceability save regular cleaning. Attention to the following points will ensure a long and useful service life with minimum need for repair.

Cleaning

During indoor use, the only cleaning required should be a regular wipe over with a lint-free cloth. Dirt accumulated during storage may be removed using a semi-stiff brush. Particular attention should be paid to the ball mounting face of the head, the space between the tilting assembly and the base and the mounting bowl of the tripod.

Use out-of-doors under adverse conditions will require special attention. Salt spray should be washed off with fresh water at the earliest opportunity. Sand and dirt acts as an abrasive and should be removed using a semi-stiff brush or vacuum cleaner.

CAUTION! DO NOT use solvent or oil-based cleaners, abrasives or wire brushes to remove accumulations of dirt, as these damage the protective surfaces. Use only detergent-based cleaners.

Routine maintenance

During use, check the following:

- Check the effectiveness of the pan and tilt brakes. Reset as necessary.

- Check the effectiveness of the tripod leg clamps. Reset as necessary.

- Check for ageing and cracking of the rubber foot securing straps on the spreader and renew if necessary.

No further routine maintenance is required.



Adjustments

Pan brake knob adjustment

Because its movement is restricted, the pan brake knob (10) may require adjustment after prolonged use.

To adjust the pan brake knob (Fig. 7):

Remove the securing screw (10.1) and pull the knob (10) off the shaft (10.2).

Turn the shaft (10.2) clockwise until the pan brake is fully applied.

Install the knob (10) on the shaft (10.2) positioned just beyond right angles (clockwise) to the body of the head.

Turn the knob fully counterclockwise and ensure the brake is released. Turn the knob clockwise and ensure the brake is applied before the knob reaches the end of its travel.

Readjust as necessary and secure the knob with the screw (10.1).

Tilt brake knob adjustment

The tilt drag knob (13) may also require adjustment after prolonged use:

To adjust the tilt brake knob (Fig. 7):

Remove the securing screw (13.1) and pull the knob (13) off the shaft (13.2).

Turn the shaft (13.2) clockwise until the pan brake is fully applied.

Install the knob (13) on the shaft (13.2) with the lever approximately horizontal in a 3 o'clock position, pointing toward the rear of the head.

Turn the knob counterclockwise by half a turn and ensure the brake is released. Turn the knob clockwise and ensure the brake is applied before the knob reaches the end of its travel or interferes with other head controls.

Readjust as necessary and secure the knob with the screw (13.1).



Back

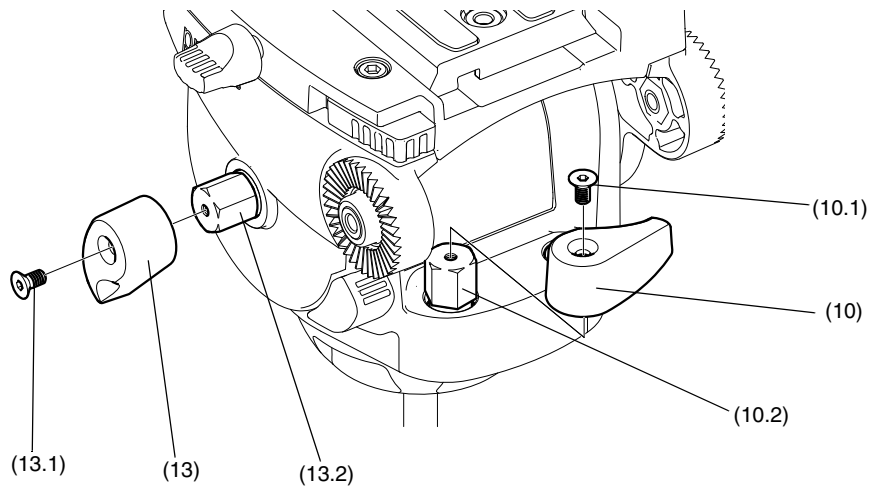

Fig. 7 Pan and Tilt brake adjustments

‘Pozi-Loc’ tripod leg clamp adjustment

Bedding-in occurs with ‘Pozi-Loc’ leg clamps, which may necessitate resetting the clamp. Check the effectiveness of each leg clamp and adjust as follows (Fig. 8):

Turn the clamp knob (19) to the vertical, ‘off’ position.

Remove screw (19.1). Using a suitable peg spanner, back off the threaded insert (19.2) slot by slot until the leg is free to move under its own weight.

While sliding the leg in and out, gradually tighten the threaded insert (19.2) until the clamp begins to grip.

If not aligned, back off the threaded insert (19.2) until a slot aligns with the hole for screw (19.1).

Back off the threaded insert (19.2) a further three slots.

Install screw (19.1) to secure the threaded insert (19.2).



Back

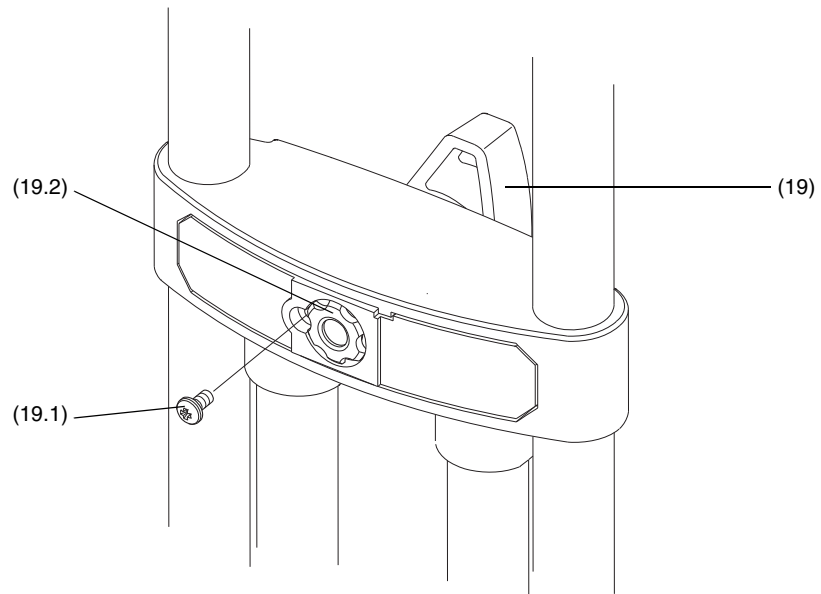

Fig. 8 Pozi-Loc tripod leg clamp



[Back](#)

Parts list

The following lists include main assemblies, user-replaceable spare parts and optional accessories. For further information regarding repair or spare parts, please contact Vinten or your local Vinten distributor.

For information on-line, visit our website at

www.vinten.com

Pro-5plus System

PRO-5^{plus} pan and tilt head, ENG Pozi-Loc single-stage tripod and floor spreader

PRO5 AP1 F

Carrying case

Soft case for Protouch systems

U005-190

User-replaceable spare parts

Pan bar

U005-620

Optional accessories

Carrying strap

Carrying strap

3425-3P

Mid-level spreader

V4032-0001

Set of three feet (for use with mid-level spreaders)

3378-902SP

Dollies

PD114 dolly

U005-103

ENG (OB) dolly

3319-3B

ENG (Studio) dolly

3319-3C

ENG (OB) dolly - small

3319-3ST

Tripod and pedestal adaptors

75 mm ball to 100 mm bowl adaptor

U005-159



[Back](#)

Warranty Details and Terms and Conditions

Please read the Warranty Details and Terms and Conditions below.

Register your product to get One Extra Years Warranty and a Free Vinten Quality Gift.

Please register now on-line at www.vinten.com/register—it's easy and fast.

The product serial number location (27) is shown in [Fig. 9](#).

Warranty

Vinten warrants, to the original purchaser only, that this product will be free from defects in materials and workmanship under normal and proper usage for a period of one (1) year from the date of purchase. Vinten's obligation under this warranty is limited to replacing or repairing, at Vinten's option, products or parts determined by Vinten to be defective in materials or workmanship. This Vinten parts and labour warranty is subject to the terms and conditions set forth below.

Extended Warranty

By registering on-line, the warranty on Vinten hardware products described above is extended from one (1) to two (2) years from the date of purchase subject to the terms and conditions below.

Terms and Conditions

Notification of Warranty Claims

All warranty claims must be made in writing and must include date and proof of purchase

Extent of liability

This warranty is given to the original purchaser of the goods only and cannot be assigned, except with the prior written agreement of Vinten.

Subject to these terms and conditions, Vinten will repair or replace, free of charge, any product or defective part provided that the defective part of the product has been returned to Vinten or its authorized agent, freight pre-paid.

If any defective product has been superseded and cannot be repaired, replacement will be made with a current model of the same quality and equivalent function.

Exclusion of Liability

This warranty does not cover any damage, defects or costs caused by: (1) modification, alteration, repair or service of the product by anyone other than Vinten or its authorized representative; (2) physical abuse to, overload of, or misuse of, the product, or operation of the product in a manner contrary to the instructions accompanying the product; (3) any use of the product other than that for which it was intended; or (4) shipment of the product to Vinten for service.

UNDER NO CIRCUMSTANCES SHALL VINTEN BE LIABLE FOR ANY SPECIAL, INCIDENTAL OR CONSEQUENTIAL DAMAGES, INCLUDING, BUT NOT LIMITED TO, PERSONAL INJURY, PROPERTY DAMAGE, DAMAGE TO OR LOSS OF EQUIPMENT, LOST PROFITS OR REVENUE, COSTS OF RENTING REPLACEMENTS AND OTHER ADDITIONAL EXPENSES, EVEN IF VINTEN HAS BEEN ADVISED OF THE POSSIBILITY OF SUCH DAMAGES. SOME JURISDICTIONS DO NOT ALLOW THE EXCLUSION OR LIMITATION OF INCIDENTAL OR CONSEQUENTIAL DAMAGES, SO THE ABOVE LIMITATION OR EXCLUSION MAY NOT APPLY TO YOU.

ANY EXPRESS WARRANTY NOT PROVIDED HEREIN, AND ANY REMEDY WHICH, BUT FOR THE WARRANTY CONTAINED HEREIN, MIGHT ARISE BY IMPLICATION OR OPERATION OF LAW IS HEREBY EXCLUDED AND DISCLAIMED INCLUDING THE IMPLIED WARRANTIES OF



[Back](#)

MERCHANTABILITY AND OF FITNESS FOR A PARTICULAR PURPOSE. SOME JURISDICTIONS DO NOT ALLOW LIMITATIONS ON IMPLIED WARRANTIES, SO THE ABOVE LIMITATION MAY NOT APPLY TO YOU.

THIS WARRANTY GIVES YOU SPECIFIC LEGAL RIGHTS AND YOU MAY ALSO HAVE OTHER RIGHTS, WHICH MAY VARY FROM JURISDICTION TO JURISDICTION.

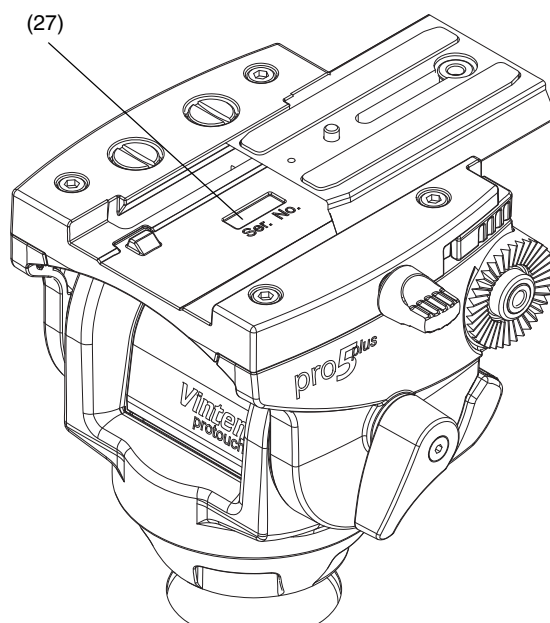

Fig. 9 Serial Number Location



Back

Vinten

CHINA

The Vitec Group plc China
Room 1806, Hua Bin Building
No.8 Yong An Dong Li
Jian Guo Men Wai Ave
Chao Yang District
Beijing, P.R.China 100022
Tel: +86 10 8528 8748
Fax: +86 10 8528 8749

FRANCE

Camera Dynamics sarl
171, Avenue des Grésillons
92635 GENNEVILLIERS Cedex
France
Tel: +33 820 821 336
Fax: +33 825 826 181

GERMANY

Camera Dynamics GmbH
Gebäude 16
Planiger Straße 34
55543 Bad Kreuznach
Germany
Tel: +49 671 / 483 43 30
Fax: +49 671 / 483 43 50

Camera Dynamics GmbH
Erfurter Straße 16
85385 Eching
Germany
Tel: +49 89 / 321 58 200
Fax: +49 89 / 321 58 227

JAPAN

Vinten Japan KK
P.A. Bldg. 5F
3-12-6 Aobadai
Meguro-ku Tokyo 153-0042
Japan
Tel: +81 3 5456 4155
Fax: +81 3 5456 4156

SINGAPORE

Camera Dynamics Pte Ltd
6 New Industrial Road
#02-02 Hoe Huat Industrial Building
Singapore 536199
Tel: +65 6297 5776
Fax: +65 6297 5778

UK

Camera Dynamics Ltd
William Vinten Building
Western Way
Bury St. Edmunds
Suffolk IP33 3TB
England
Tel: +44 1284 752 121
Fax: +44 1284 750 560
Sales Fax: +44 1284 757 929

USA

Camera Dynamics Inc.
709 Executive Blvd
Valley Cottage
NY 10989
USA
Tel: +1 845 268 0100
Fax: +1 845 268 0113
Toll Free Sales: +1 888 2 Vinten

Vinten Website www.vinten.com

Information contained in this document is subject to change.

Vinten reserves the right, without notice, to make changes in equipment design or performance as progress in engineering, manufacturing or technology may warrant.

Publication Part No. V4057-4980-EN