

Operators Guide

Osprey *Light*

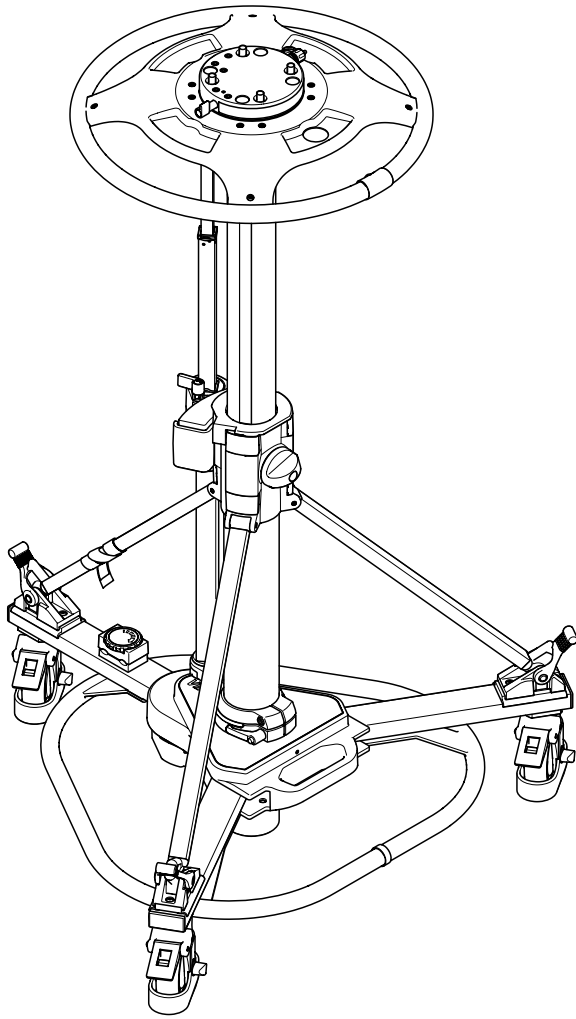

Pedestal



Vinten
Camera Control Solutions



[Back](#)

Osprey *Light* **Pedestal**

Publication Part No. V3950-4980
Issue 2 (November 2007)

Copyright © Vitec Group plc 2007

All rights reserved throughout the world. No part of this document may be stored in a retrieval system, transmitted, copied or reproduced in any way including, but not limited to, photocopy, photograph, magnetic or other record without the prior agreement and permission in writing of Vitec Group plc.

Vinten® and Quickfix® are registered trademarks of Vitec Group plc.

Printed in Great Britain by DPS, Newmarket, Suffolk



Back

Understanding these instructions

English

- (EN)** The original instructions presented in this operators guide were written in English, and subsequently translated into other languages. If you are unable to understand these instructions, contact Vinten or your distributor to obtain a translation of the original instructions (EU Countries).

БЪЛГАРСКИ

- (BG)** Оригиналните инструкции, представени в настоящото ръководство на производителя, бяха написани на английски език, а след това - преведени на други езици. Ако не разбирате тези езици, свържете се с Vinten или с Вашия дистрибутор, за да получите оригиналните инструкции (за страните от Европейския съюз).

Česky

- (CS)** Pokyny uvedené v této operátorské příručce byly původně napsány anglicky a následně byly přeloženy do ostatních jazyků. Nerozumíte-li těmto pokynům, kontaktujte společnost Vinten nebo svého distributora, abyste získali překlad originálních pokynů (členské státy EU).

Danish

- (DA)** De originale instruktioner, der præsenteres i denne betjeningsvejledning, er skrevet på engelsk og derefter oversat til andre sprog. Hvis du ikke forstår disse instruktioner bedes du kontakte Vinten eller vor forhandler for at få en oversættelse af de originale instruktioner (EU-lande).

Deutsch

- (DE)** Die Originalanleitung in diesem Bedienungshandbuch wurde auf Englisch verfasst und anschließend in andere Sprachen übersetzt. Bei Verständnisproblemen in einer der übersetzten Sprachen kontaktieren Sie bitte Vinten oder Ihren Fachhändler; dort erhalten Sie eine Übersetzung der ursprünglichen Anleitung (EU-Staaten).

Eesti

- (ET)** Käesoleva kasutajjuhendi algtekst on koostatud inglise keeles ning seejärel tõlgitud teistesse keeltesse. Kui juhend osutub teie jaoks arusaamatuks, võtke juhendi emakeelse tõlke hankimiseks ühendust Vinteni või kohaliku esindajaga (Euroopa Liidu riigid).

Ελληνικά

- (EL)** Οι αρχικές οδηγίες αυτού του οδηγού για το χειριστή συντάχθηκαν στα Αγγλικά και μεταφράστηκαν στη συνέχεια σε άλλες γλώσσες. Εάν δυσκολεύεστε να καταλάβετε αυτές τις οδηγίες, επικοινωνήστε με τη Vinten ή το διανομέα σας για να λάβετε μια μετάφραση των αρχικών οδηγιών (Χώρες ΕΕ).

Español

- (ES)** Las instrucciones originales que se indican en esta guía del operador se han redactado en inglés y posteriormente se han traducido a otros idiomas. Si no entiende estas instrucciones, póngase en contacto con Vinten o con su distribuidor para obtener una traducción de las instrucciones originales (para países de la UE).

Français

- (FR)** Les instructions originales présentées dans ce guide d'utilisation ont été écrites en anglais puis traduites dans d'autres langues. Si vous ne comprenez pas ces instructions, contactez Vinten ou votre revendeur pour obtenir une traduction des instructions originales (pour les pays de l'UE).



Back

Gaeilge

- GA** Scríobhadh na treoracha bunaidh don treoirleabhar oibritheora seo as Béarla, agus aistríodh iad go teangacha eile ina dhiaidh sin. Mura bhfuil tú in ann na treoracha seo a thuiscint, téigh i dteagmháil le Vinten nó le do dháileoir, chun aistriúchán de na treoracha bunaidh a fháil (Tíortha an AE).

Italiano

- IT** Le istruzioni originali presentate in questa guida per l'operatore sono in lingua inglese e successivamente tradotte nelle altre lingue. Qualora le istruzioni non fossero disponibili nella lingua desiderata, potete contattare Vinten o il vostro distributore per ricevere la traduzione delle istruzioni originali (Paesi UE).

Latviešu

- LV** Šajā operatora rokasgrāmatā iekļautie norādījumi sākotnēji tika sarakstīti angļu valodā un pēc tam pārtulkoti citās valodās. Ja nesaprotat šos norādījumus svešvalodā, sazinieties ar Vinten vai tirgotāju, lai saņemtu norādījumu tulkojumu (kādā no ES dalībvalstu valodām).

Lietuvių

- LT** Šiame operatoriaus vadove pristatomos pirminės instrukcijos parašytos anglų kalba ir vėliau išverstos į kitas kalbas. Jei šių instrukcijų nesuprantate, susisiekite su „Vinten“ arba savo platintoju ir gaukite pirminių instrukcijų vertimą (ES šalies kalba).

Magyar

- HU** A kezelői útmutatóban található utasítások angol nyelven íródtak, és utólag fordították azokat más nyelvekre. Ha nem érti ezen utasításokat, kérjük, vegye fel a kapcsolatot a Vintennel vagy a helyi képviselővel, és igényelje az eredeti utasítások fordítását (EU országok).

Malti

- MT** L-istruzzjonijiet originali ipprezentati f'din il-gwida ta' operaturi kienu miktuba bl-Ingliż, u sussegwentement maqluba fl-lingwi oħra. Jekk ma tistax tifhem dawn l-istruzzjonijiet, ikkuntattja lil Vinten jew id-distributur tieghek biex tikseb traduzzjoni ta' l-istruzzjonijiet originali (Pajjiżi ta' UE).

Nederlands

- NL** De oorspronkelijke instructies in deze bedieningshandleiding zijn geschreven in het Engels en vervolgens in andere talen vertaald. Als het onmogelijk is deze instructies te begrijpen, neemt u contact op met Vinten of met uw distributeur om een vertaling te bemachtigen van de oorspronkelijke instructies (EG-landen).

Polski

- PL** Oryginalne instrukcje zamieszczone w niniejszym podręczniku operatora zostały napisane w języku angielskim, a następnie przetłumaczone na inne języki. Jeśli nie rozumieją Państwo tych instrukcji, prosimy skontaktować się z siedzibą lub dystrybutorem Vinten, aby uzyskać tłumaczenie oryginalnych instrukcji (kraje UE).

Português

- PT** As instruções originais apresentadas no guia do operador foram escritas em Inglês e traduzidas para outros idiomas. Se não conseguir compreender estas instruções contacte a Vinten ou o seu distribuidor para obter a tradução das instruções originais (Países da UE).



Back

Română

- RO** Instrucțiunile originale prezentate în acest ghid pentru operatori au fost scrise în limba engleză, și traduse ulterior în alte limbi. În cazul în care nu înțelegeți aceste instrucțiuni, contactați Vinten sau distribuitorul dumneavoastră pentru a obține o traducere a instrucțiunilor originale (Țările UE).

Slovensky

- SK** Pôvodné pokyny, uvedené v tomto návode na obsluhu, boli napísané v angličtine a následne preložené do iných jazykov. Ak nerozumiete týmto pokynom, obráťte sa na spoločnosť Vinten alebo vášho distribútora, aby vám zaslal preklad originálnych pokynov (krajinu EÚ).

Slovenščina

- SL** Originalno besedilo teh navodil za uporabo je bilo napisano v angleščini in prevedeno v ostale jezike. Če ne razumete teh navodil, se obrnite na podjetje Vinten ali lokalnega zastopnika, ki vam bo posređoval originalna navodila (velja za dr_ave EU).

Suomi

- FI** Tähän käyttäjän oppaaseen sisältyvät ohjeet on kirjoitettu alun perin englanniksi ja käännetty sitten muille kielille. Ellet ymmärrä näitä ohjeita, ota yhteyttä Vinteniin tai jälleenmyyjään ja pyydä alkuperäisten ohjeiden käännöstä (EU-maat).

Svenska

- SV** Instruktionerna i denna handbok skrevs ursprungligen på engelska och har sedan översatts till flera språk. Om du inte förstår dessa instruktioner, kontakta Vinten eller din återförsäljare för en ny översättning av originalinstruktionerna (EU-länder).



Back

Preface

Thank you and congratulations on your new Osprey *Light* pedestal from Vinten

We want you to get the most from your new pedestal, and therefore encourage you to read this operators guide to familiarise yourself with its many features, some of which may be new to you. It also covers essential health and safety information and a section on maintenance that will ensure you keep your new product in perfect condition.

To receive additional benefits, register with Vinten now, on line by visiting www.vinten.com/register, or by completing the enclosed form.

Features and benefits of your new Osprey *Light* pedestal

The Osprey Light pedestal has been specifically designed to meet the exacting demands of camera operators working with lightweight studio cameras. The Osprey Light pedestal offers a high level of control with many unique features.

- **Suitable for a wide range of professional lightweight studio camera/pan and tilt head configurations up to 40 kg (88 lb).**
- **Small footprint allows the pedestal to access tight set situations**
- **All three wheels are permanently locked together to provide crab steering**
- **Built-in pump means that the pedestal can be pressurised at any location**
- **On-shot stroke of 54 cm (21.3 in.) and a maximum height of 131.8 cm (51.9 in.) provide increased creative angles**
- **Pedestal breaks down into skid and column for easy transportation**

Once again, thank you for choosing the Osprey *Light* pedestal

We are confident it will give you many years of reliable performance



Back

Safety - read this first

English—Original Instructions

The original instructions presented in this operators guide were written in English, and subsequently translated into other languages. If you are unable to understand any of the translated languages, contact Vinten or your distributor to obtain a translation of the original instructions (EU Countries).

Warning Symbols in this Operators Guide



Where there is a risk of personal injury, injury to others, or damage to the pedestal or associated equipment, comments appear, highlighted by the word **WARNING!** and supported by the warning triangle symbol.

Warning symbols on the pedestal

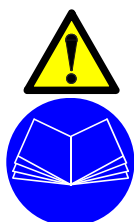

On encountering the warning triangle or open book symbols it is imperative that you consult this operators guide before using the pedestal or attempting any adjustment or repair.

Critical data

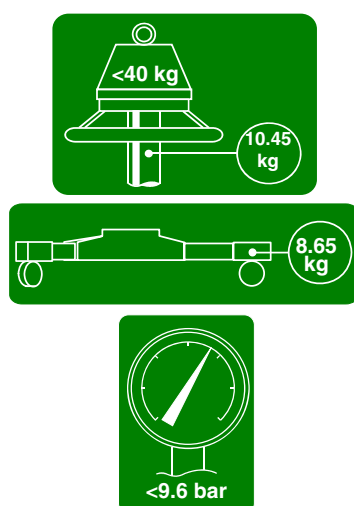

Load

Maximum load 40 kg (88 lb)

Mass

Column 10.45 kg (23 lb)

Skid - studio 8.45 kg (18.6 lb)

Skid - OB 8.65 kg (19 lb)

Kick ring 2.5 kg (5.5 lb)

Pressure

Maximum pressure 9.6 bar (139 psi)



[Back](#)

Regulatory information

This product conforms to the following European Directives:



2006/42/EC (CE Marking Directive)
98/37/EC (Machinery Directive) (89/392/EC)
97/23/EC (Pressure Equipment Directive - SEP)
2001/95/EC (General Product Safety)

This product has been manufactured in accordance with BS EN ISO 9001/2000

Harmonised standards applied:

BS EN ISO 12100-2:2003 (Safety of machinery—Basic Concepts, general principles for design, Part 2: Technical principles.

BS EN 1050:1997 Safety of machinery—Principles for risk assessment.

In accordance with the following UK Regulations:

SI 1992 No.3037 Supply of Machinery (Safety) Regulations 1992

SI 1994 No.2063 Supply of Machinery (Safety) Regulations—Amendment 1994

SI 1999 No.2001 (SI 2002/1267) UK Pressure Equipment Regulations 1994



Back

Contents

	Page
Preface	6
Safety - read this first	7
Critical data	7
Regulatory information	8
Technical data	10
Usage	10
Further information	11
Introduction	14
Operation	15
Assembling the pedestal	15
Setting the control valve	16
Pressurizing the pedestal	17
Fitting and balancing the load	22
Using the pedestal	24
Transportation and storage	26
Servicing	28
General	28
Routine checks	28
Adjustments	28
Parts List	31

Associated Publication

Osprey Light Pedestal
Maintenance Manual and illustrated Parts List
Publication Part no. V3959-4990



Back

Technical data

	STUDIO	OB
Payload	40 kg (88 lb)	40 kg (88 lb)
Column weight	10.45 kg (23 lb)	10.45 kg (23 lb)
Skid weight	8.45 kg (18.6 lb)	8.65 kg (19 lb)
Kick ring weight	2.5 kg (5.5 lb)	2.5 kg (5.5 lb)
Total pedestal weight (without kick ring)	18.9 kg (41.6 lb)	19.1 kg (42 lb)
Trim weights (4 x 1.0 kg) auxiliary (6 x 0.5 kg)	4.0 kg (8.8 lb) 3.0 kg (6.6 lb)	4.0 kg (8.8 lb) 3.0 kg (6.6 lb)
Minimum height	76.5 cm (30.1 in.)	77.8 cm (30.6 in.)
Maximum height	130.5 cm (51.4 in.)	131.8 cm (51.9 in.)
On-shot stroke	54 cm (21.3 in.)	54 cm (21.3 in.)
Ground clearance	10 cm (0.4 in.)	2.25 cm (0.9 in.)
Doorway tracking width	80.6 cm (27.5 in.)	80.6 cm (27.5 in.)
Transit doorway width	70 cm (27.5 in.)	70 cm (27.5 in.)
Wheel diameter	10 cm (4 in.)	12.5 cm (5 in.)
Steering ring diameter	50 cm (19.7 in.)	50 cm (19.7 in.)
Maximum working pressure	9.6 bar (139 psi)	9.6 bar (139 psi)
Minimum working pressure	2 bar (29 psi)	2 bar (29 psi)
Relief valve pressure	10 bar (145 psi)	10 bar (145 psi)
Internal capacity	1.9 L (0.50 gal)	1.9 L (0.50 gal)
Operational temperature	-20°C / +60°C (-4°F / +140°F)	-20°C / +60°C (-4°F / +140°F)

Usage

The Osprey Light pedestal is designed for use in television studios and on location to support and balance a pan and tilt head, camera and ancillary equipment weighing up to 40 kg (88 lb).

This product is intended for use on an unobstructed and reasonably level surface by television camera operators.



- WARNING!**
- 1. Do NOT attempt to use this product if you do not understand how to operate it.**
 - 2. Do NOT use this product for any other purpose than that specified in the Usage statement above.**
 - 3. Maintenance beyond that detailed in this Operators Guide must be performed only by competent personnel in accordance with the procedures laid down in the Maintenance Manual.**
-
-



Back

Further information

For further information or advice regarding this pedestal, please contact Camera Dynamics Limited, your local Vinten distributor (see back cover) or visit our website.

For details on maintenance and spare parts, please refer to the Osprey Light Pedestal Maintenance Manual and Illustrated Parts List (Publication Part No. V3950-4990) This is obtainable from Vinten Broadcast Limited or your local Vinten distributor. For information on-line, visit our website at

www.vinten.com.



Back

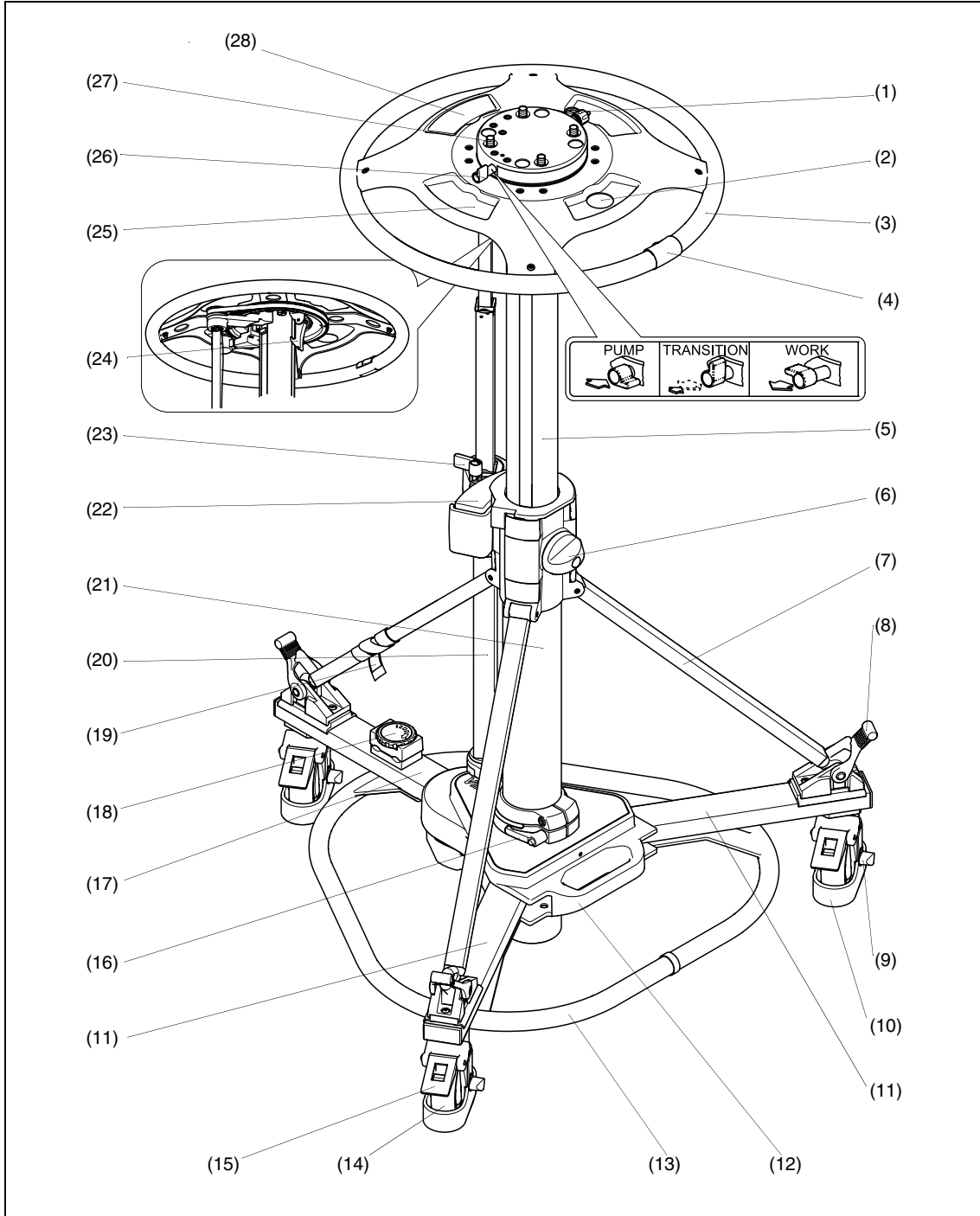

Fig 1 Osprey Light Pedestal (Studio Version)



[Back](#)

Osprey Light Pedestal (Studio Version)

- (1) Schrader valve and cap
- (2) Pressure gauge viewing window
- (3) Steering ring
- (4) Steering indicator
- (5) Moving column
- (6) Drag control knob/on-shot clamp
- (7) Strut
- (8) Foot support and strap
- (9) Cable guard adjustment knob
- (10) Cable guard
- (11) Folding leg
- (12) Skid centre casting
- (13) Optional kick ring
- (14) Skid wheel
- (15) Brake
- (16) Skid clamp
- (17) Fixed leg
- (18) Cable clamp
- (19) Velcro strap
- (20) Steering tube
- (21) Outer tube
- (22) Trim weight stowage
- (23) Trim weight catch
- (24) Safety catch
- (25) Weight tray pocket
- (26) Control valve
- (27) Four-bolt mounting plate
- (28) Trim weight



[Back](#)

Introduction

The Osprey Light pedestal is a fully-portable pneumatic camera mount, designed to support a payload of up to 40 kg (88 lb). It is available in OB and Studio versions.

The pedestal has a central single-stage telescopic column, supported on a skid assembly with crabbing wheel steering. To facilitate transport, the telescopic column and skid may be separated and the skid folded.

The pedestal may be pressurized using the built-in pump, Vinten Portable Pump or an external pressure source. The pedestal is equipped with a relief valve to prevent an excessive build-up of pneumatic pressure and with a safety catch to prevent accidental operation of the telescopic column. The pressure relief valve operates at the predetermined level and automatically resets at a designated level below this.

The skid assembly comprises a centre casting, three equispaced skid legs and three braked wheels. The OB version has 12.5 cm (5.0 in.) wheels, the Studio version has 10 cm (4.0 in.) wheels fitted with cable guards.



Back

Operation

Assembling the pedestal Skid

Turn the skid upside-down, depress the leg locking plungers (11.1) and swing each folding leg (11) out until the plungers lock the legs in the fully open position.

NOTE: The kick ring can be fitted in only one position, with the shorter strut on the fixed leg.

Fit the optional kick ring (13), which is secured by three sliding catches (13.1) to spigots (12.1) on the underside of the centre casting.

Set the skid on the ground on its wheels and apply the wheel brakes (15).

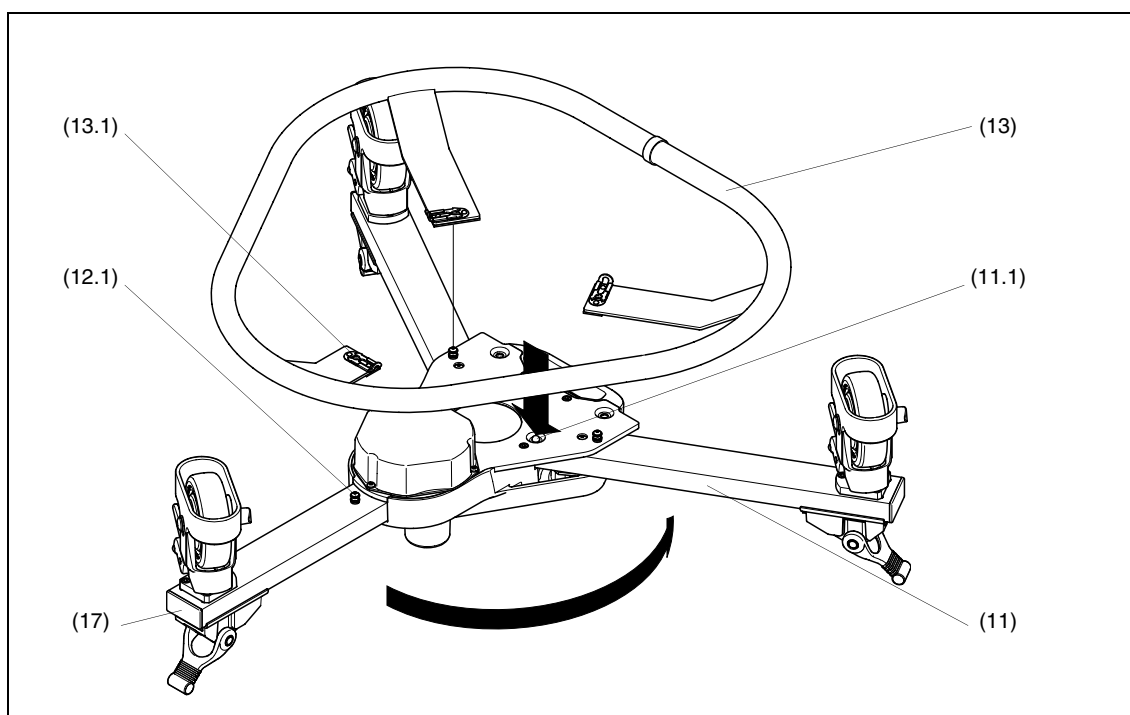

Fig 2 Assembling the skid



Back

Column

Install the column on the skid as follows:

Fully slacken the skid clamp (16) and ensure that the rubber straps (8) on each foot support are to the outside of the ball joint.

Ensure the control valve (26) is set to the WORK position.

Release the Velcro retaining strap (19).

Hold the telescopic column upright with the steering ring uppermost and swing the three struts (7) up almost to horizontal.

Lift the column assembly by the steering ring (3) and lower it vertically into the skid centre casting, ensuring that the steering tube (20) engages correctly with the skid. Turn the steering ring to fully engage the steering tube (20).

Engage the struts (7) on the foot supports (8) and secure each strut to the foot support with the rubber strap.

Tighten the skid clamp (16), using moderate hand pressure only. The clamp lever has a spring-loaded ratchet-type action and is operated as follows:

Turn the clamp lever (16) clockwise as far as possible.

Pull the lever outward against the spring pressure, return it to vertical and release.

Turn lever clockwise again.

Repeat until the skid clamp is sufficiently tightened.

Secure the Velcro retaining strap (19) clear of the skid wheels.

Slide the steering indicator (4) to the desired position.

Setting the control valve

The control valve (26) safely switches the pedestal between PUMP and WORK modes, and has three distinct positions and functions.

Pump

Pump mode isolates the moving column (5) from the full pedestal pressure and engages the built-in pump mechanism. To select PUMP mode, proceed as follows:

Depress the control valve (26) against the spring force, and rotate the lever fully clockwise to a horizontal position. The control valve (26) will remain in a depressed position.

Refer to [Pressurizing the pedestal using the built-in pump](#) on page 19 for self-pumping instructions.

NOTE: Set the control valve (26) to PUMP mode when transporting the pedestal, to isolate the moving column (5) from internal pressure. Refer to [Transportation and storage](#) on page 26 for more information.



Back

Transition

Transition mode gradually applies the full pedestal pressure to the moving column (5) at a safe rate. To select TRANSITION mode, proceed as follows:

Fully extend the moving column (5).

Depress the control valve (26) against the spring force, rotate the lever to the vertical position and allow the lever to extend under the spring force.



WARNING! Place the control valve (26) in the TRANSITION position for at least 10-SECONDS when switching between PUMP and WORK modes, to prevent the moving column (5) rising rapidly.

Work

Work mode applies the full pedestal pressure to the moving column (5) to balance the payload. To select WORK mode, proceed as follows:

Ensure the moving column (5) is fully extended.

Depress the control valve (26) against the spring force, and rotate the lever fully counter clockwise to a horizontal position, allowing the lever (26) to extend under the spring force. The control valve (26) will remain in an extended position.

NOTE: The pressure gauge only displays full system pressure when the control valve (26) is set to WORK.

Pressurizing the pedestal

The Osprey Light pedestal may be pressurized manually using the self-contained pump, Vinten portable pump (Part No. 3357-3) or an external pressure source.

A correctly pressurized pedestal will balance its payload, allowing movement over the full on-shot stroke of the moving column with minimum effort, and will maintain its position when the steering ring is released. Balance can be adjusted by adding or removing trim weights (28) to the weight tray pockets (25), or venting some of the internal pressure.

Ascertain the payload to be fitted to the pedestal (payload = pan and tilt head, camera, trim weights, lens and all ancillary equipment). Referring to the [Pressurization Graph](#), mark the payload on the horizontal axis then strike a vertical line from the load figure to the balance line. At the intersecting point, strike a horizontal line to the vertical axis and read off the required gas pressure.

The pedestal pressure must be reduced to a maximum of 3.5 bar (50 psi) before fitting the pan and tilt head (refer to [Fitting and balancing the load](#) on page 22 for more detail).

NOTE: Reducing pedestal pressure below 3.5 bar (50 psi) may cause a pressure leak.



Back



WARNING! 1. Do NOT pressurize the pedestal beyond the maximum safe working pressure indicated by the leading edge of the red sector on the gauge.

2. Do NOT adjust the pressure relief valve. Personal injury and pedestal damage may occur.

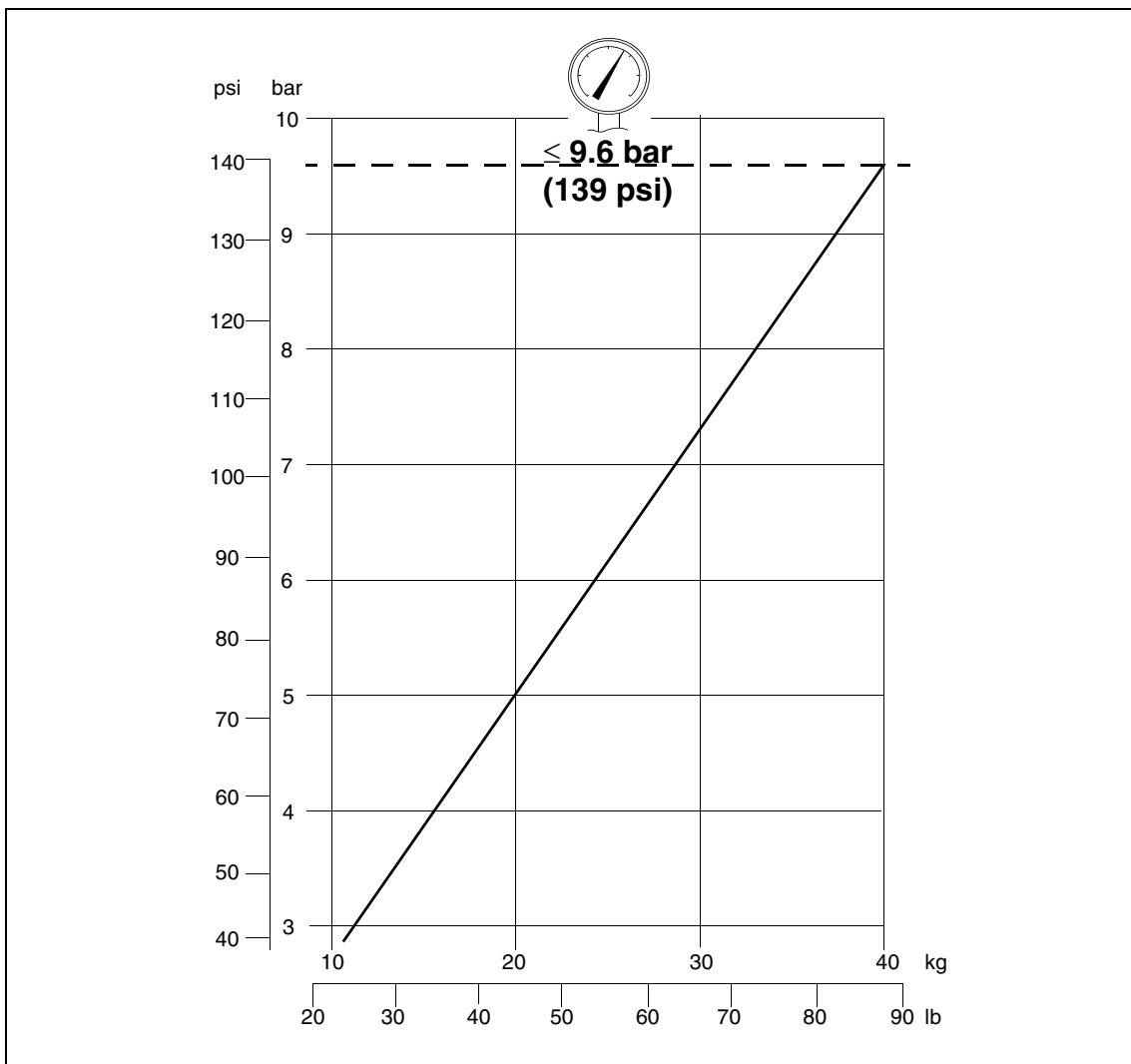

Fig 3 Pressurization Graph



Back

To determine the pedestal pressure, proceed as follows:

Ensure that the control valve (26) is set to the WORK position (refer to [Setting the control valve](#) on page 16).

Rotate the steering ring (3) so that the pressure gauge is visible through the viewing window (2).

Pressurizing the pedestal using the built-in pump

To pressurize the pedestal using the built-in pump, proceed as follows:

Apply the wheel brakes (15).

Set the control valve (26) to the PUMP position as follows:

Depress the control valve (26) against the spring force, and rotate the lever fully clockwise to a horizontal position. The control valve (26) will remain in a depressed position.

Push down on the steering ring (3) against any residual pressure and release the safety catch (24). Set the safety catch in the horizontal position.

Rotate the steering ring (3) so that the pressure gauge (2) is visible through the window.



WARNING! If fitted, remove the camera from the pan and tilt head before attempting to use the built-in pump. The pan and tilt head can remain fitted without compromising operator safety.

Using the steering ring (3), raise the top stage (5) until fully extended. Commence pumping by lowering and raising the top stage (5) over the upper half of its travel. When the pressure gauge (2) begins to register, pump the top stage over its full stroke.

As pressure increases, put a foot on the skid to restrain the pedestal on the up stroke.

NOTE: The pressure gauge only displays full system pressure when the control valve (26) is set to WORK.

An approximation of the final pedestal pressure can be obtained by observing the peak pressure reading on the downward pumping stroke.

Stop pumping when the required pressure is reached ([Fig 3](#)) during the pumping stroke. Do not exceed the maximum working pressure, indicated by the leading edge of the red sector on the gauge (2).

NOTE: Do not exceed 3.5 bar (50 psi) if the pan and tilt head has yet to be fitted. For further information refer to [Fitting and balancing the load](#) on page 22.



Back

Fully collapse the moving column (5) and apply the safety catch (24).

Set the control valve (26) to the TRANSITION position as follows:

Depress the control valve (26) against the spring force, rotate the lever to the vertical position and allow the lever to extend under the spring force.



WARNING! Place the control valve (26) in the TRANSITION position for at least 10-SECONDS when switching between PUMP and WORK modes, to prevent the moving column (5) rising rapidly.

Set the control valve (26) to the WORK position as follows:

Ensure the moving column (5) is fully collapsed and the safety catch (24) is applied.

Depress the control valve (26) against the spring force, and rotate the lever fully counter clockwise to a horizontal position, allowing the lever (26) to extend under the spring force. The control valve (26) will remain in an extended position.

Pressurizing the pedestal using the Vinten portable pump

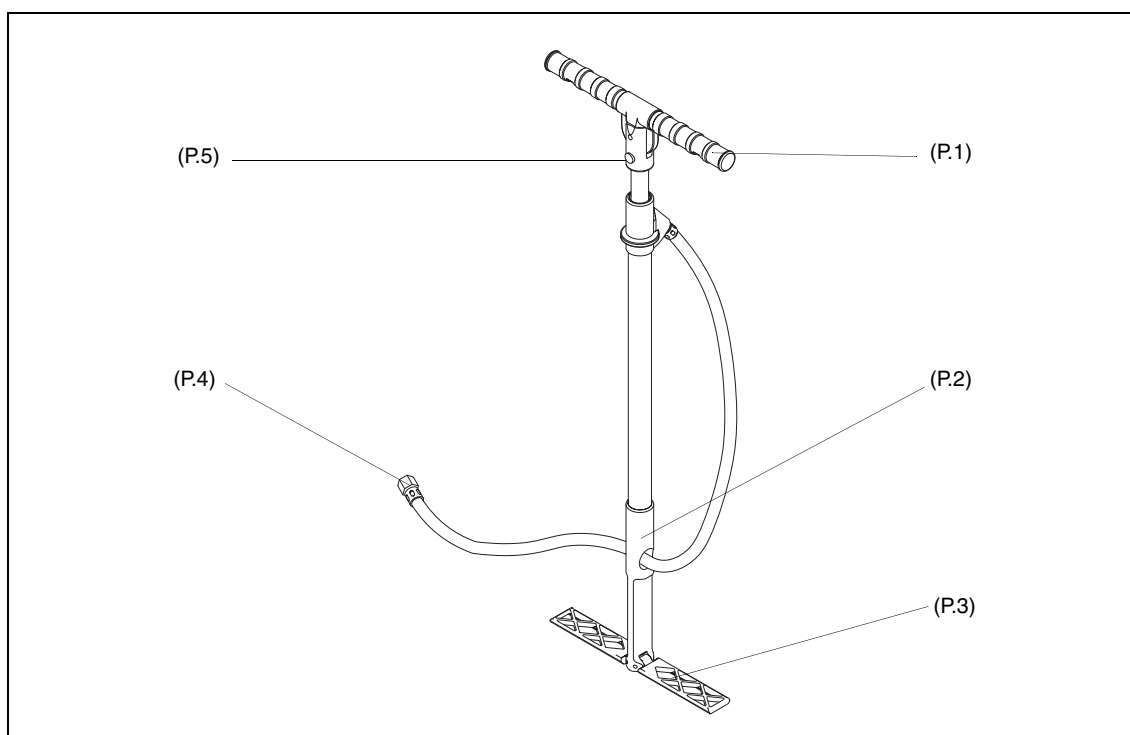

Fig 4 The Vinten Portable Pump



Back

To pressurize the pedestal using the Vinten portable pump, proceed as follows:

Fully collapse the moving column (5) and apply the safety catch (24).

Set the control valve (26) to the WORK position (refer to [Setting the control valve](#) on page 16 for more detail).

Rotate the steering ring (3) so that the pressure gauge is visible through the viewing window (2).

On the pump (Fig 4), fold down both the feet (P.3).

Depress the handle release button (P.5) and move the handle (P.1) to the horizontal position, where it will lock.

Pull the hose (P.4) out of its stowage (P.2). Connect the hose to the pedestal charging valve.

Position the pump between the legs, standing with both feet on the fold-down feet (P.3).

Grip the handle (P.1) with both hands and, using full steady strokes, pressurize the pedestal to the required pressure. Do not exceed the maximum working pressure, indicated by the leading edge of the red sector on the gauge (2).

NOTE: Do not exceed 3.5 bar (50 psi) if the pan and tilt head has yet to be fitted. For further information refer to [Fitting and balancing the load](#) on page 22.

Disconnect the hose (P.4) from the pedestal charging valve, but do not refit the Schrader valve cap at this stage. Fit the hose in its stowage (P.2).

Push the pump plunger fully down, depress the handle release button (P.5) and move the handle (P.1) to the vertical position, where it will lock the pump plunger in the closed position.

Fold up both the feet (P.3).

Pressurizing from an external pressure source

A pressure reducing valve must be fitted between the gas cylinder and the outlet connection of the hose. The maximum pressure on the outlet side of the reducing valve must not exceed 9.6 bar (139 psi).



WARNING! This pedestal must be pressurized only with clean, dry air or nitrogen.

To pressurize the pedestal from an external pressure source, proceed as follows:

Fully collapse the moving column (5) and apply the safety catch (24).

Set the control valve (26) to the WORK position (refer to [Setting the control valve](#) on page 16 for more detail).

Rotate the steering ring (3) so that the pressure gauge is visible through the window (2).



Back

Remove the Schrader valve cap (1) and connect the charging line from the pressure source.

Turn on the pressure supply and slowly increase the pedestal pressure to the required pressure. Do not exceed the maximum working pressure, indicated by the leading edge of the red sector on the gauge (2).

NOTE: Do not exceed 3.5 bar (50 psi) if the pan and tilt head has yet to be fitted. For further information refer to [Fitting and balancing the load](#) below.

Disconnect the charging line, but do not refit the Schrader valve cap at this stage.

Fitting and balancing the load

The Osprey Light pedestal has the standard four-bolt mounting plate (27) which permits the use of various Vinten camera mounts including pan and tilt heads, Quickfix and Mitchell adapters.

Fitting the camera mount

To fit the camera mount, proceed as follows:

Ensure that the control valve (26) is set to the WORK position (refer to [Setting the control valve](#) on page 16).

Rotate the steering ring (3) so that the pressure gauge is visible through the viewing window (2).



WARNING! 1. Do NOT release the safety catch if the pedestal pressure exceeds 3.5 bar (50 psi) without a balancing load installed. Reduce as necessary, using the Schrader valve cap

2. Do NOT lean over the pedestal. An over pressurized pedestal may rise rapidly when the safety catch is released, causing personal injury.

Push down on the steering ring (3) against any residual pressure, release the safety catch (24) and allow the column to extend fully using the steering ring (3) under hand restraint.

Apply the on shot clamp (6).

Fit the camera mount (including the pan and tilt head) to the four-bolt fixing mounting plate (27), securing the bolts from the underside of the weight tray.

Fitting the camera

There are two different procedures for fitting the camera and ancillary items, depending on the pedestal pressurization method.

To fit the camera and ancillary items, and balance with an external pressure source, proceed as follows:

Fully collapse the moving column (5) and apply the safety catch (24).



Back

Fit the camera and all remaining ancillary items such as pan bars, prompters, lenses etc. Attaching these items at a later stage may upset the pedestal balance.

Pressurize the pedestal to balance the full payload (refer to either [Pressurizing the pedestal using the Vinten portable pump](#) on page 20, or [Pressurizing from an external pressure source](#) on page 21).

Place a trim weight (28) onto the weight tray (25).

NOTE: To remove a trim weight (28) from the trim weight stowage (22), first rotate the trim weight catch (23) through half a turn anti-clockwise.

Replace the trim weight catch (23) afterwards to retain remaining stowed trim weights (22).



WARNING! Do NOT lean over the pedestal when releasing the safety catch. An over pressurized pedestal may rise rapidly when the safety catch is released, causing personal injury.

Push down on the steering ring (3) against any residual pressure and release the safety catch (24). Set the safety catch in the horizontal position and extend the column using the steering ring (3) under hand restraint.

If the column tends to fall, remove a trim weight (28) from the weight tray (25).

If the column rises, use the Schrader valve cap (1) to carefully reduce the pressure in steps of 0.15- 0.20 bar (2-3 psi) until the payload is correctly balanced. A correctly pressurized pedestal will balance its payload such that it may be moved to any position over the full on-shot stroke with minimum effort, and will maintain its position when the steering ring is released.

NOTE: The Schrader valve cap (1) forms a primary pressure seal. Always replace the cap and screw it down finger-tight.

The pedestal is now ready for use.

To fit the camera and ancillary items and balance using the built-in pump, proceed as follows:

Pressurize the pedestal to balance the full payload (refer to [Pressurizing the pedestal using the built-in pump](#) on page 19).

Fully collapse the moving column (5) and apply the safety catch (24).

Fit the camera and all remaining ancillary items such as pan bars, prompters, lenses etc. Attaching these items at a later stage may upset the pedestal balance.



Back

Place a trim weight (28) onto the weight tray (25).

NOTE: To remove a trim weight (28) from the trim weight stowage (22), first rotate the trim weight catch (23) through half a turn anti-clockwise.

Replace the trim weight catch (23) afterwards to retain remaining stowed trim weights (22).



WARNING! Do NOT lean over the pedestal when releasing the safety catch. An over pressurized pedestal may rise rapidly when the safety catch is released, causing personal injury.

Push down on the steering ring (3) against any residual pressure and release the safety catch (24). Set the safety catch in the horizontal position and extend the column using the steering ring (3) under hand restraint.

If the column tends to fall, remove a trim weight (28) from the weight tray (25).

If the column rises, use the Schrader valve cap (1) to carefully reduce the pressure in steps of 0.15- 0.20 bar (2-3 psi) until the payload is correctly balanced. A correctly pressurized pedestal will balance its payload such that it may be moved to any position over the full on-shot stroke with minimum effort, and will maintain its position when the steering ring is released.

NOTE: The Schrader valve cap (1) forms a primary pressure seal. Always replace the cap and screw it down finger-tight.

The pedestal is now ready for use.

Using the pedestal

Height adjustment

The column has an on-shot stroke of 54 cm (21.3 in.) and the load can be moved over this distance, in perfect balance, by raising and lowering the steering ring (3).

Column movement can be damped as required, by setting the drag control knob (6) located at the top of the fixed column (21). Turn the knob (6) clockwise to increase the drag setting, and counter-clockwise to decrease it.

If fixed height operation is required, turn the knob fully clockwise to lock the moving column in position.

Brakes

The skid is fitted with a brake on each wheel. The brakes are applied by pressing down on the lever (15) situated above the wheel and released by pressing down on the centre 'pop-up' lever which is raised when the brake is on.



[Back](#)

Cable guards

The cable guards (10) fitted to the studio version are height-adjustable and should be set as required. Adjustment is carried out by slackening the knobs (9), setting the cable guards at the required height and re-tightening the knobs.

Cable clamp

A cable clamp (18) is provided on the fixed leg of the skid.

Crab steering

Directional control of the pedestal is achieved by rotating the steering ring (3) mounted at the top of the column. This rotates all three aligned wheels simultaneously, providing crab steering.

The steering system is geared so that the skid wheels turn by the same amount as the steering ring. This ensures, for example, that turning the steering ring by 90° will also cause the pedestal to change direction by 90°.

The steering ring is fitted with a movable indicator (4) which can be used to mark the straight-ahead position of the ring and thus provide a reference point.



Back

Transportation and storage



WARNING! 1. Local, national or international regulations may apply to the transport and storage of pressurized pedestals.

2. The control valve (26) **MUST** be set to the **WORK** position when degassing the pedestal, or only the pump volume will be vented and the tank volume will remain.

3. Reducing the pedestal pressure below 3.5 bar (50 psi) will cause the remaining pressure to leak.

NOTE: It is not necessary to reduce the pedestal pressure prior to transportation or storage. However, it is recommended to set the control valve (26) to **PUMP**, to isolate the moving column (5) from the internal pressure.

Set the column to minimum height to avoid the possibility of dust or abrasive particles collecting on moving components.

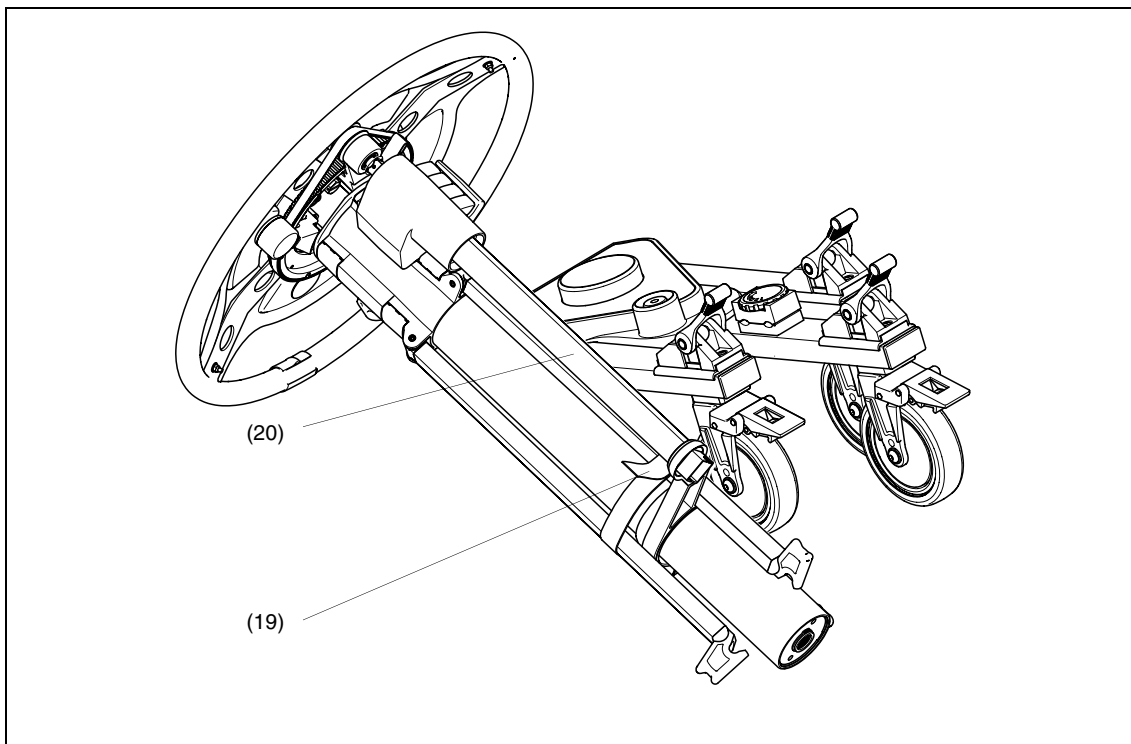

Fig 5 Transportation and Storage



Back



WARNING! ALWAYS collapse the moving column (5) and engage the safety catch (24) if wheeling the pedestal across uneven/inclined surfaces between shots with the full payload fitted, to prevent loss of stability.

The pedestal may be dismantled for transportation and storage. Proceed as follows:

Apply the brakes (15).

Fully depress the moving column (5) and engage the safety catch (24).

Set the control valve (26) to PUMP (refer to **Setting the control valve** on page 16 for more information).



WARNING! Ensure that the payload is removed before dismantling the pedestal.

Remove the payload.

Secure all trim weights (28) in the trim weight stowage (22) using the stowage catch (23).

Release the skid clamp (16).

Release the three rubber foot straps (8) from the struts.

Raise the struts (7), then lift the complete column vertically off the skid.

Secure the struts with the Velcro strap (19).



WARNING! The column will be unstable if stood on its base.

Remove the kick ring (13) from the skid by releasing the sliding catches (13.1).

Depress the locking plungers (11.1) and fold the skid legs (11), ensuring that the plungers lock in the fully closed position.



[Back](#)

Servicing

General

The Osprey Light pedestal is robustly made to high engineering standards and little attention is required to maintain serviceability save regular cleaning. Attention to the following points will ensure a long and useful service life with minimum need for repair.

Cleaning

During normal studio use, the only cleaning required should be a regular wipe over with a lint-free cloth. Dirt accumulated during storage or periods of disuse may be removed with a semi-stiff brush. Particular attention should be paid to the track strips on the moving column.

NOTE: Do NOT use oil or grease on any exposed part of the column. This is unnecessary and traps dirt which acts as an abrasive.

Use out-of-doors will require special attention, especially in adverse conditions. Salt spray must be washed off with fresh water at the earliest opportunity. Do not allow water to enter the column. Sand and dirt acts as an abrasive and should be removed with a semi-stiff brush or vacuum cleaner.

NOTE: Use only detergent-based cleaners. Do NOT use solvent- or oil-based cleaners, abrasives or wire brushes to remove accumulations of dirt, as these damage the protective surfaces.

Routine checks

Check the following during normal use:

- Check for ageing and cracking of the rubber strut securing straps and renew if necessary.
- Check the effectiveness of the drag control and skid clamp. Adjust if necessary.
- Check for radial or side play in the moving column. Adjust if necessary.
- Check the condition of the safety catch. Arrange a product service if necessary.

Adjustments

Adjustments that may become necessary after considerable use are as follows:

- Taking up wear in the drag control knob.
- Taking up wear in the skid clamp.
- Elimination of radial and side play in the moving column.
- Steering adjustments.



Back

Drag control knob adjustment

When turned fully clockwise, the 'V' notch on the drag control knob should be within the limits shown. To adjust the drag control knob:

Turn the drag control knob fully clockwise.

Remove the hole plug (6.1). Remove the screw (6.2) and washer (6.3) securing knob (6) to the spindle (6.4).

Remove the knob, then replace on spindle (6.4) so that the 'V' notch on the knob is within the limits shown.

Degrease screw (6.2), coat with Loctite 222E and secure knob with washer (6.3) and screw (6.2). Replace hole plug (6.1).

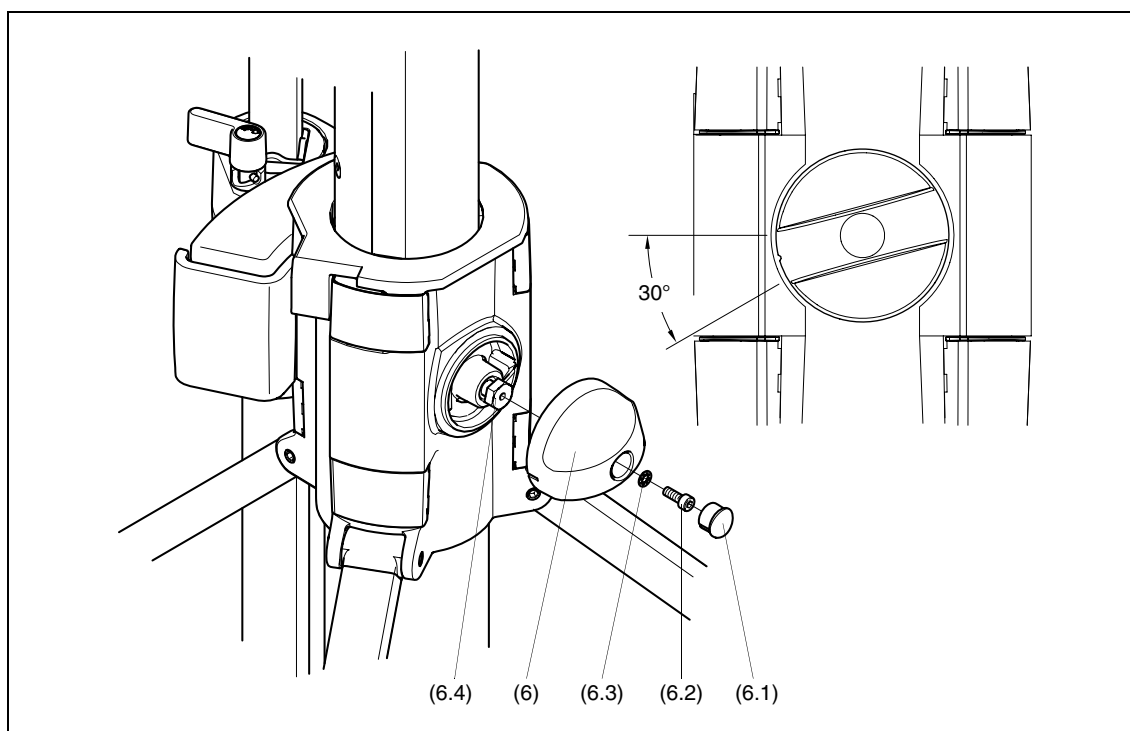

Fig 6 Drag knob adjustment

Skid clamp adjustment

To adjust the skid clamp (16):

The skid clamp is applied or released by turning the handle clockwise or counter-clockwise. The handle has a pull-off/push-on ratchet adjustment. To take up wear, pull the handle away from the spindle, rotate counter-clockwise and release.

Repeat the above procedure, as necessary, until the clamp locks when applied but allows free movement when released.



[Back](#)

Elimination of radial and side play in the moving column

If excessive radial or side play is apparent in the moving column, refer to the appropriate section in the Maintenance Manual. This adjustment should be carried out by a competent person.

Steering adjustments

Inaccuracies in steering may be due to slackness in the steering belt or steering chains, or inaccurate tracking. Checking and adjustment should be carried out by a competent person as described in the appropriate section of the Maintenance Manual.



[Back](#)

Parts List

The following list includes the main assemblies, user replaceable spare parts and optional accessories. For further information regarding repair or spare parts, please contact Vinten Broadcast Limited or your local distributor.

Main assemblies

Osprey Light studio version (10 cm wheels and cable guards)	V3950-0001
Osprey Light OB version (12.5 cm wheels)	V3950-0002
Column	V3950-1001
Studio skid	V3950-1101
OB skid	V3950-1105

Optional accessories

100 mm levelling bowl	3330-16
150 mm levelling bowl	3330-17
Heavy-duty Quickfix adaptor	3490-3
Kick ring	V3950-1109
Vinten portable pump	3357-3
Spanner for head bolts	J551-001
Tracking base adaptor	V3950-1110
For use with tracking base	3369-57